

A High-Voltage “Boost” Capacitor Charger

In this paper, we will look at the design and efficiency of a high-voltage capacitor charger, in which a step-up transformer operates in “normal” transformer mode. That is, currents flow in the primary and secondary circuits at the same time. The principal components of the circuit we will examine are shown in the following schematic diagram. Some readers will recognize this as a schematic produced by SPICE. SPICE was used to carry out the simulations which are described below.

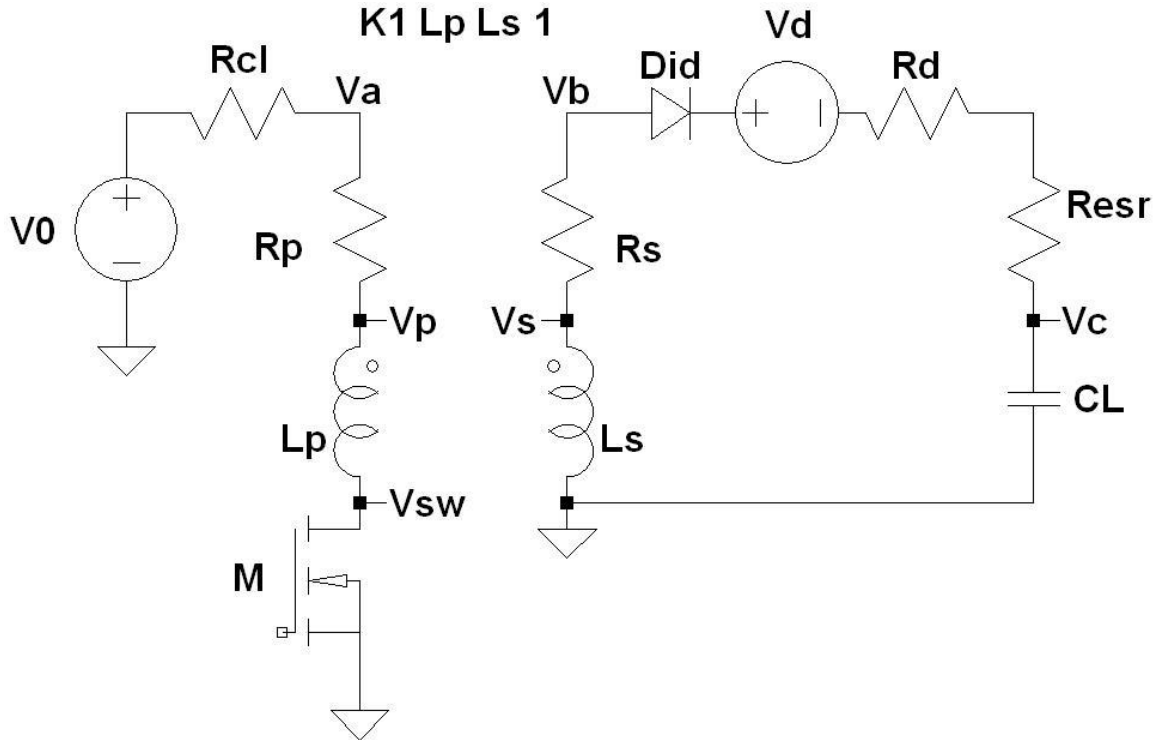

The goal of the circuit is to charge the load capacitor C_L . A basic assumption is that capacitor C_L will be charged up to some target voltage or energy and then discharged suddenly into some load circuit. (The schematic diagram does not show the load circuit.)

The effective series resistance R_{esr} of the load capacitor is shown explicitly in the diagram. Of course, the effective series resistance is an integral part of the load capacitor, and is not a separate component, but we need to represent it separately in order to develop a mathematically model for the circuit.

Rectification is provided by an ideal diode D_{id} , whose non-ideal features are represented by a constant forward voltage drop of V_d and a forward series resistance of R_d . Leakage current under reverse bias will be ignored.

The transformer is represented by the inductance L_p of its primary winding and inductance L_s of its secondary winding. The transformer is assumed to be ideal in the sense that it enjoys zero leakage, but non-ideal in having Ohmic resistances (that is, resistance in the wire) in the primary and secondary windings of R_p and R_s , respectively. The orientation of the transformer is such that, when the current flowing into the dotted end of the primary winding increases, a positive voltage is generated between voltage point v_s and ground. Since the goal of this circuit is to charge the load capacitor to a high voltage, it is understood that the secondary winding will have a great many more turns, and therefore much higher inductance, than the primary winding.

Resistor R_{cl} is a current-limiting resistor placed in the primary circuit to protect the power supply from excessive current flow. The power supply V_0 is a constant voltage dc source.

The primary circuit is periodically interrupted by switch M , an n-channel enhancement mode MOSFET. The circuit which drives the gate of switch M is not shown in the schematic.

Once again, I will point out the significance of the way this circuit operates: current will flow in the transformer's primary and secondary circuits at the same time. This is the traditional mode in which a transformer operates and is to be distinguished from a "buck-boost" type of circuit. (A similar circuit, configured as a "buck-boost" charger, is described in another document.)

Before delving into this circuit too far, it is useful to determine realistic values for the components. Indeed, it is best to specify the components, or at least how they can be constructed, so that we do not end up with a circuit which cannot be built.

Overall design specifications

- The target voltage for the capacitor is 4000V.
- The target energy to be stored in the capacitor is 800J.
- The power supply can deliver 2A of current at a voltage of 12V.

It immediately follows that:

- The turns ratio of the transformer must be $4000V:12V = 333:1$.
- The energy equation for a charged capacitor, $E = \frac{1}{2}CV^2$, requires that capacitance $C_L = 100\mu F$.
- Since the power supply delivers 24W of power, the theoretical charging time at 100% efficiency will be $800J/24W = 33.3s$. At lower efficiencies, charging will take longer.
- Assuming that the forward resistance of the MOSFET is small and that the Ohmic resistance of the primary winding is small, the only meaningful resistance in the primary circuit is resistor R_{cl} . If it is to limit the flow of current to 2A, its value must be $R_{cl} = 12V/2A = 6\Omega$.

The load capacitor C_L

Because the load capacitor in this circuit is intended for sudden discharge, it should have as low a series resistance as practical. The series resistance does not just sop up power when the capacitor discharges – it also limits the speed with which the capacitor can be discharged. Electrolytic capacitors, despite other shortcomings, score well on this characteristic.

A useful starting point is a common 250V 2200 $\mu F \pm 20\%$ capacitor, such as Digikey part number P10052-ND. It has an equivalent series resistance of 90m Ω at a frequency of 120Hz, decreasing to 45m Ω at a frequency of 20KHz.

Suppose we wire twenty two (22) of these capacitors in series. This will give:

- $C_L = 2200\mu F / 22 = 100\mu F$.
- $R_{esr} = 22 \times 90m\Omega = 1.98\Omega \cong 2\Omega$.
- Voltage rating = $22 \times 250V = 5500V$.

The voltage rating is 37% higher than the target voltage. Note that these capacitors cost about \$14.00 each, so the lot will cost \$308.

The transformer

In order to minimize leakage, a toroidal transformer will be used. Since the switching frequency will be relatively high, the toroid should have a ferrite core.

Newark sells a ferrite core, part number 07R5397, which should suit. The core is made by EPCOS and is their part number B64290L40x830. It has inner and outer diameters of 30.5mm and 60.1mm, and a thickness of 19.3mm. The following sketch of the core is approximately to scale.

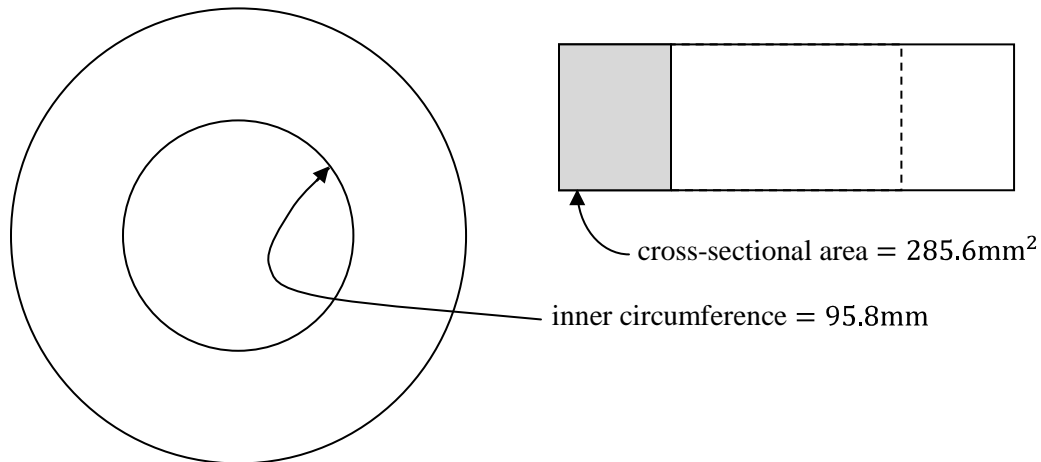

The manufacturer states the customary parameters for a toroidal core, being:

- Effective circumference $A_e = 152.4\text{mm}$.
- Cross-sectional area $A_{cs} = 285.6\text{mm}^2$.
- (Initial) relative permeability $\mu_i = 4300$.

The first step is to determine the maximum number of Ampere – turns this core can handle. The core is made from a material identified as “N30”, which has its own data sheet. The important characteristic of N30 is that it saturates at a magnetic field intensity of 240mT at a temperature of 100°C.

We can use the standard formula to calculate the magnetic field intensity at the center of the cross-section of a toroidal core (with all variables expressed in SI units). Letting μ_0 be the permeability of free space, N be the number of turns and I the current flowing through the turns, the magnetic field intensity is equal to:

$$\begin{aligned} B &= \frac{\mu_0 \mu_i N I}{A_e} \\ \rightarrow B_{sat} &\geq \frac{\mu_0 \mu_i (N I)_{max}}{A_e} \\ \rightarrow (N I)_{max} &\leq \frac{B_{sat} A_e}{\mu_0 \mu_i} \\ &\leq \frac{0.240 \times 0.1524}{4\pi \times 10^{-7} \times 4300} \\ &\leq 6.77 \text{ Ampere – turns} \end{aligned}$$

Since we have specified that the power supply can (or should) operate at 2A, the number of turns in the primary winding must be less than 3.4 in order that $(NI)_{max}$ be kept less than 6.8. Let us decide to use three turns in the primary winding, rather than reduce the primary current in order to enable more turns.

Then, the secondary winding should have 333 times as many turns, or 999 turns.

Suppose we wind the secondary winding with #30 gauge magnet wire, which Newark also sells, as its part number 36F1310. This wire requires linear spacing of 91.7 turns/inch. The inner circumference of the core is long enough to hold $(98.5\text{mm} / 25.4\text{mm/inch}) \times 91.7 \text{ turns/inch} = 356 \text{ turns}$.

The number of layers in the secondary winding will be $999 \text{ turns} / 356 \text{ turns/layer} = 2.8 \text{ layers}$. While one might be able to squeeze 356 turns into the bottom layer, the outer layers, which will have a reduced circumference to lie on, must have fewer turns.

What we will do is this: we will wind an average of 350 turns in each of 3 layers, giving a total number of turns equal to $3 \text{ layers} \times 350 \text{ turns/layer} = 1050 \text{ turns}$. (That this number of turns exceeds the 999 turns required is a personal preference – I am always skeptical about the effectiveness of that last quarter-turn in the primary winding.)

Now, let us calculate the length of wire needed. As shown in the figure above, the cross-section of the core has a width of $(60.1\text{mm} - 30.5\text{mm})/2 = 14.8\text{mm}$ and a height of 19.3mm, giving a nominal perimeter of $2 \times (14.8\text{mm} + 19.3\text{mm}) = 68.2\text{mm}$. However, the thickness of the wire itself adds to the effective perimeter of the outer layers. Let us assume that the outer diameter of the wire is $1 / 91.7 \text{ turns/inch} = 0.01091 \text{ inch} = 0.277\text{mm}$. Let us assume that we will coat each layer in the winding with transformer varnish and that the varnish coat will be 0.25mm thick. Then, looking from the surface of the core outwards, the secondary winding will consist of three layers of wire separated by two layers of varnish. The average height of the layers' centers from the surface of the core will be equal to $(1.5 \times 0.277\text{mm}) + (1 \times 0.25\text{mm}) = 0.666\text{mm}$. The average perimeter of all the turns will be equal to $2 \times [(14.8 + 0.666 + 0.666) + (19.3 + 0.666 + 0.666)]\text{mm} = 73.5\text{mm}$.

The length of wire needed will be $1050 \text{ turns} \times 73.5\text{mm/turn} = 77,175\text{mm} = 253 \text{ feet}$. The wire, which is Beldon #8055, has a resistance of $0.1037\Omega/\text{foot}$, so the winding will have a total resistance of $253 \text{ feet} \times 0.1037\Omega/\text{foot} = 26.2\Omega$. (Incidentally, the standard coil of this wire, as sold by Newark, contains just over 1600 feet of wire.)

The primary winding will be wrapped around the secondary winding. We will use some heavy gauge wire for this purpose. Let us suppose that the total resistance of this winding is 0.1Ω , which should be enough to include the joints where the leads of the primary winding are soldered to the printed circuit board.

Next, we need to estimate the inductances of the windings. Using the standard formula for toroidal cores with a circular shape (with all quantities converted to SI units), the inductance of the secondary winding will be equal to:

$$\begin{aligned} L_s &= \frac{\mu_0 \mu_i A_{cs} N_s^2}{A_e} \\ &= \frac{(4\pi \times 10^{-7})(4300)(285.6 \times 10^{-6})(1050^2)}{152.4 \times 10^{-3}} \\ &= 11.2\text{H} \end{aligned}$$

The primary winding, with its 3 turns, will have an inductance equal to:

$$L_p = \frac{(4\pi \times 10^{-7})(4300)(285.6 \times 10^{-6})(3^2)}{152.4 \times 10^{-3}} \\ = 91.1\mu\text{H}$$

Before finishing up with the transformer, we should ensure that everything else will be satisfactory. We have already made sure that the primary's Ampere-turns should not saturate the core. In addition:

- The N30 core material is designed to be used in the range of frequencies from 10KHz to 400KHz. This suggests that the period of the charge-discharge cycles at which we operate the circuit should be in the range from 2.5 μ s to 100 μ s.
- The #30 gauge wire used in the secondary winding has a maximum recommended current of 140mA. In our case, with a primary current of 2A, the secondary current will be approximately 1/333 as much, or 6mA. This is well within the capability of the wire. In fact, we could use finer wire for the secondary winding.
- The wire has double insulation – polyurethane with a nylon overcoat. Even so, its breakdown voltage at room temperature is 2075V. Transformer varnish between the layers will add some extra protection but, even so, potential breakdown will be an issue. The best remedy will be to wind the secondary in sections along the circumference of the core. In order to leave a gap between the first and last sections, it will be necessary to more than three layers in each section. Appendix A attached describes a plan for winding the secondary to overcome the limited insulation breakdown voltage.

The values we will use when analyzing the circuit are the following:

- $L_s = 11.2\text{H}$.
- $L_p = 91.1\mu\text{H}$.
- $R_s = 26.2\Omega$.
- $R_p = 0.1\Omega$.
- Charge-discharge cycle time should be in the range from 2.5 μ s to 100 μ s.

The rectifier diode

The challenge is to get a high-voltage diode with both a fast recovery time and a low leakage current. The diode's forward current capacity should not be a significant issue, since the current in the secondary circuit will only be 6mA or so. Similarly, the forward voltage drop over the diode should not be a significant issue, and will be negligible when compared with the several KiloVolts we propose to place on the capacitor.

It seems to me that the MUR8100EG diode, made by ON Semiconductors and sold by Newark as its part number 88H4948, is a reasonable place to start. It has a reverse recovery time of 75ns and a reverse breakdown voltage of 1000V. I propose to use six of these diodes in series. That will give a combined reverse breakdown voltage of 6000V, which is 50% more than the target voltage of 4000V.

The datasheet for this diode states that, at a forward current of 500mA (far more than we will experience), the forward voltage drop is typically equal to 0.96V. That corresponds to a forward resistance of $0.96\text{V}/0.5\text{A} = 1.92\Omega$. Six such diodes in series will have a combined forward voltage drop of $6 \times 0.96\text{V} = 5.8\text{V}$. Since our forward current is so far below 500mA, we will model the diode solely by its

forward voltage drop, with no additional resistance. To be clear about this point, the diode's series resistance, which was represented as component R_d in the schematic above, will be ignored.

The datasheet gives a nominal reverse current of $1\mu\text{A}$ at 800V . This corresponds to a reverse resistance of $800\text{V}/1\mu\text{A} = 800\text{M}\Omega$. The reverse resistance of six such diodes in series will be $6 \times 800\text{M}\Omega = 4.8\text{G}\Omega$. When subject to a reverse voltage of 4000V , the six diodes will leak current of about $4000\text{V}/4.8\text{G}\Omega = 0.83\mu\text{A}$. What is the effect of this leakage current on the voltage over the capacitor? Let us make an estimate.

Over the course of ten seconds, this current will carry charge from the load capacitor C_L in the amount of $\Delta Q = I \times \Delta t = 0.83\mu\text{A} \times 10\text{s} = 8.3\mu\text{C}$. If the capacitor is initially charged to 4000V , then it holds charge in the amount of $Q_i = CV_i = 100\mu\text{F} \times 4000\text{V} = 0.4\text{C}$. Ten seconds later, the capacitor's charge will have decreased to $Q' = Q_i - \Delta Q = 0.4\text{C} - 8.3\mu\text{C} = 0.3999917\text{C}$ and the capacitor's voltage will have decreased to $V' = Q'/C = 0.3999917\text{C} / 100\mu\text{F} = 3999.92\text{V}$. So, after the capacitor is charged, it will lose about 8mV in ten seconds because of leakage through the diode. This is minor. (Of course, the capacitor will also leak all throughout the charging process.)

In any event, the combined diode should be characterized by:

- $V_d = 5.8\text{V}$.
- $R_d = 0$.
- $R_{reverse} = 4.8\text{G}\Omega$ for SPICE simulation purposes.

The MOSFET

I like hexfets made by International Rectifier Corporation. IRC's IRFP4668 may suit this application.

The IRFP4668's nominal ON-resistance is given as $8\text{m}\Omega$. As always, this is a nonsense figure. It applies only if the junction is somehow kept at room temperature. More realistic resistances can be derived directly from Figure 2 of the datasheet, which plots the drain-to-source current against the drain-to-source voltage. We will be using gate-to-source voltages in the range from 6V to 12V , all of which have pretty much the same I-V characteristic. Two data points are convenient: (i) $V_{DS} = 0.1\text{V}$ when $I_{DS} = 4\text{A}$, corresponding to $R_{DS} = 0.1\text{V}/4\text{A} = 0.025\Omega$ and (ii) $V_{DS} = 2\text{V}$ when $I_{DS} = 70\text{A}$, corresponding to $R_{DS} = 2\text{V}/70\text{A} = 0.029\Omega$. Both of these points obtain when the junction temperature is a more realistic 175°C . For design purposes, we will use a conservative ON-resistance of $0.03\Omega = 30\text{m}\Omega$.

One does not normally speak about the OFF-resistance of a hexfet. Normally, the constraint on the design will be the length of time required to charge and/or discharge the gate capacitance. In due course, below, we will get into these timing particulars. For now, we will simply use an arbitrarily large number, say, $1\text{M}\Omega$, for the MOSFET's OFF-resistance.

The IRFP4668 has a drain-to-source breakdown voltage of 200V . We will need to ensure that transient voltage spikes across the MOSFET do not exceed this voltage.

For the MOSFET, then, we will use the following characteristics:

- $R_{on} = 0.03\Omega$.
- $R_{off} = 1\text{M}\Omega$.
- Breakdown will occur at $V_{DS} = 200\text{V}$.

Part #1 – A single charging cycle

The following figure shows the schematic diagram for the above circuit, with the component values now shown. This schematic will be used for a SPICE simulation of the charging cycle. Since we will be looking at a “charging cycle” only, as opposed to a “discharging cycle”, the MOSFET has been replaced by its ON-resistance R_{on} .

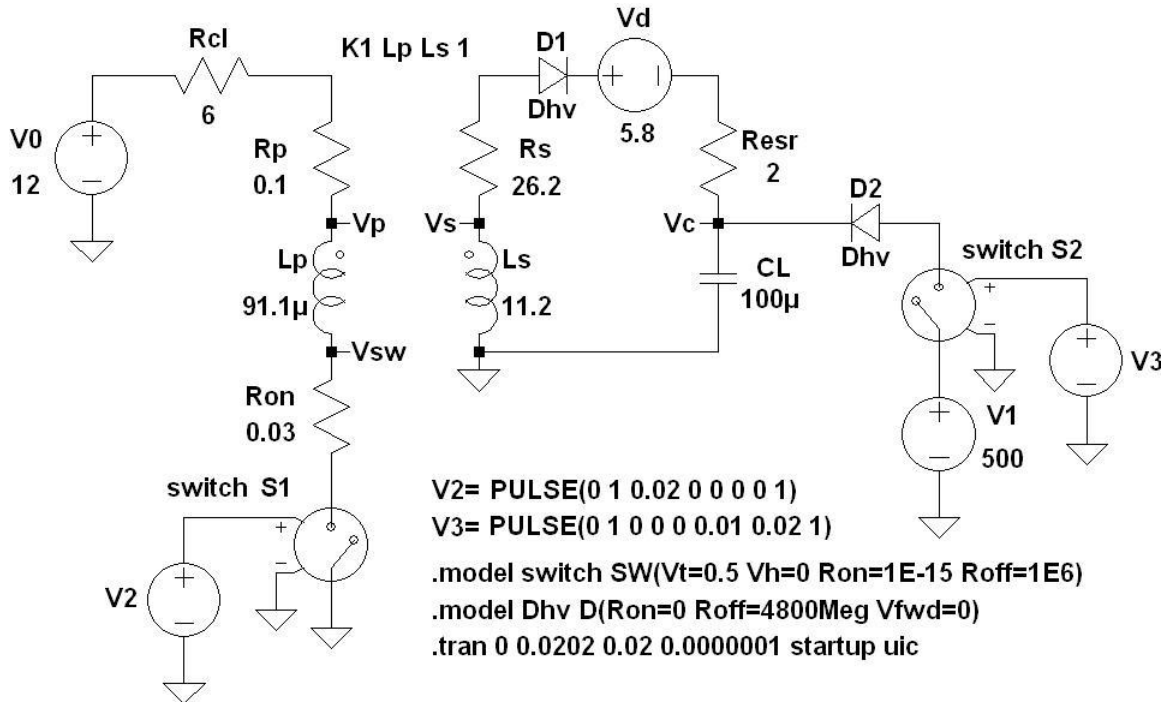

I must say a word about diode D_2 , the three new voltage sources V_1 , V_2 and V_3 and the two ideal switches S_1 and S_2 . They have been included so that the SPICE simulation gets the initial conditions right. The sub-circuit feeding diode D_2 puts the desired amount of initial voltage onto the capacitor. One should note that a capacitor which is initially charged to some voltage $v_c|_0$ does not behave in the same way as an uncharged capacitor in series with a dc voltage of $v_c|_0$. In order to model the circuit properly in (my version) of SPICE, it is necessary to explicitly charge the capacitor up to the desired initial voltage. Voltage source V_1 is a dc voltage source at the desired initial voltage of the capacitor, in this case, 500V. S_2 is a simple SPST switch, whose operation is controlled by voltage source V_3 . The SPICE directive for V_3 shows that the switch closes at simulation time $t_{sim} = 0$ and opens 10ms later. The capacitor charges up during the time the switch is closed. D_2 , S_2 , V_1 and V_3 do not do anything after the capacitor is charged.

Switch S_1 controls the primary circuit. Like S_2 , S_1 is a simple SPST switch, but its operation is controlled by voltage source V_2 . The SPICE directive for V_2 shows that it closes at simulation time $t_{sim} = 20$ ms and does not open thereafter.

These initial-condition details apply only to the SPICE model. For the purposes of a mathematical analysis, we will use a different time base, and set time $t = 0$ at the instant when the MOSFET begins conducting. We will assume that the capacitor has already been charged up to voltage $v_c|_0$ at time $t = 0$.

There are six circuit variables of interest:

- $i_p|_{total}$ is the total current flowing through the primary circuit;
- i_p is the magnetizing current flowing through the primary winding;
- $v_p - v_{sw}$ is the voltage drop over the ideal inductance in the primary winding;
- v_s is the voltage drop over the ideal inductance in the secondary winding;
- i_s is the total current flowing in the secondary winding and
- v_c is the voltage drop over the load capacitor C_L .

In order to solve for six circuit variables, we had better be able to come up with six circuit equations.

Sum of the voltage drops around the primary circuit

$$V_0 = (R_{cl} + R_p + R_{on})i_p|_{total} + (v_p - v_{sw})$$

For convenience, we will use the symbol $R_{\Sigma p} = R_{cl} + R_p + R_{on}$ to represent the sum of the series resistances in the primary circuit. Then, we can write this expression as:

$$V_0 = R_{\Sigma p}i_p|_{total} + (v_p - v_{sw}) \quad (1A)$$

Sum of the currents flowing through the primary winding

The current flowing through the primary winding will be the sum of: (i) the magnetizing current i_p and (ii) the current flowing through the secondary circuit, scaled up by the turns-ratio. Since the inductance-ratio is the square of the turns-ratio, we can write:

$$i_p|_{total} = i_p + \sqrt{\frac{L_s}{L_p}}i_s \quad (1B)$$

The magnetizing current of the primary winding

The magnetizing current is determined by the self-inductance of the primary winding. It is related to the voltage drop over the primary winding by:

$$v_p - v_{sw} = L_p \frac{di_p}{dt} \quad (1C)$$

The ratio of voltages between the two sides of the transformer

The voltage drops over the ideal inductances of the transformer are related by the turns-ratio, thus:

$$v_s = \sqrt{\frac{L_s}{L_p}}(v_p - v_{sw}) \quad (1D)$$

Sum of the voltage drops around the secondary circuit

There are two cases to consider, depending on whether diode D_1 is conducting or not:

$$\begin{aligned} v_s &= (R_s + R_{esr})i_s + V_d + v_c & (1Ea - \text{conducting}) \\ i_s &= 0 & (1Eb - \text{not conducting}) \end{aligned}$$

V-I characteristic of the load capacitor

The voltage drop over the load capacitor is related to the current flowing into it, and to its initial voltage, in the traditional manner, as:

$$v_c = \frac{1}{C_L} \int_{t=0}^t i_s dt + v_c|_0 \quad (1F)$$

As a first step to combining these six equations, we can use Equation (1B) to replace $i_p|_{total}$, Equation (1C) to replace $v_p - v_{sw}$ and Equation (1F) to replace v_c , in each case replacing them wherever else they occur. It is also useful to take the derivatives of Equation (1Ea) and Equation (1F). We get three independent equations:

$$\begin{aligned} V_0 &= R_{\Sigma p} \left(i_p + \sqrt{\frac{L_s}{L_p}} i_s \right) + L_p \frac{di_p}{dt} & (1A') \\ \frac{dv_s}{dt} &= \sqrt{L_p L_s} \frac{d^2 i_p}{dt^2} & (1D') \\ \frac{dv_s}{dt} &= (R_s + R_{esr}) \frac{di_s}{dt} + \frac{i_s}{C_L} & (1Ea' - \text{conducting}) \\ i_s &= 0 & (1Eb' - \text{not conducting}) \end{aligned}$$

It is convenient to separate the conducting and non-conducting cases, and to pursue them separately from here onwards.

Part #1A – A single charging cycle, when diode D_1 is conducting

We can re-arrange Equation (1A') to isolate variable i_s , as follows:

$$i_s = \sqrt{\frac{L_s}{L_p}} \left(-\frac{L_p}{R_{\Sigma p}} \frac{di_p}{dt} - i_p + \frac{V_0}{R_{\Sigma p}} \right) \quad (1A'')$$

We can set equal Equation (1Ea' – conducting) and Equation (1D'), which will eliminate v_s . We get:

$$\sqrt{L_p L_s} \frac{d^2 i_p}{dt^2} = (R_s + R_{esr}) \frac{di_s}{dt} + \frac{i_s}{C_L} \quad (1D'')$$

Substituting i_s from Equation (1A'') into Equation (1D'') then gives the following second-order differential equation in the magnetizing current i_p .

$$\begin{aligned} \sqrt{L_p L_s} \frac{d^2 i_p}{dt^2} &= (R_s + R_{esr}) \sqrt{\frac{L_s}{L_p}} \frac{d}{dt} \left(-\frac{L_p}{R_{\Sigma p}} \frac{di_p}{dt} - i_p \right) + \frac{1}{C_L} \sqrt{\frac{L_s}{L_p}} \left(-\frac{L_p}{R_{\Sigma p}} \frac{di_p}{dt} - i_p + \frac{V_0}{R_{\Sigma p}} \right) \\ \rightarrow L_s \frac{d^2 i_p}{dt^2} &= -(R_s + R_{esr}) \left(\frac{L_p}{R_{\Sigma p}} \frac{d^2 i_p}{dt^2} + \frac{di_p}{dt} \right) + \frac{1}{C_L} \left(\frac{L_p}{R_{\Sigma p}} \frac{di_p}{dt} + i_p - \frac{V_0}{R_{\Sigma p}} \right) \end{aligned}$$

Collecting terms gives:

$$\left[L_p + (R_s + R_{esr}) \frac{L_p}{R_{\Sigma p}} \right] \frac{d^2 i_p}{dt^2} + \left[\frac{1}{C_L} \frac{L_p}{R_{\Sigma p}} + (R_s + R_{esr}) \right] \frac{di_p}{dt} + \frac{1}{C_L} i_p = \frac{1}{C_L} \frac{V_0}{R_{\Sigma p}}$$

It helps if we define three time-constants, as follows:

- τ_p as the inductor-resistance time-constant in the primary circuit, $\tau_p = L_p / (R_{cl} + R_p + R_{on})$;
- τ_s as the inductor-resistance time-constant in the secondary circuit, $\tau_s = L_s / (R_s + R_{esr})$ and
- τ_{RC} as the resistance-capacitor time-constant in the secondary circuit, $\tau_{RC} = (R_s + R_{esr}) C_L$.

With this notation, the differential equation in the charging case can be written as:

$$(\tau_p + \tau_s) \frac{d^2 i_p}{dt^2} + \left(1 + \frac{\tau_p}{\tau_{RC}} \right) \frac{di_p}{dt} + \frac{1}{\tau_{RC}} i_p = \frac{V_0}{\tau_{RC} R_{\Sigma p}} \quad (2)$$

We can guess that a general form of solution for this differential equation will be $i_p = P e^{\beta t} + Q$.

Substitution gives:

$$(\tau_p + \tau_s) P \beta^2 e^{\beta t} + \left(1 + \frac{\tau_p}{\tau_{RC}} \right) P \beta e^{\beta t} + \frac{1}{\tau_{RC}} (P e^{\beta t} + Q) = \frac{V_0}{\tau_{RC} R_{\Sigma p}}$$

Collecting terms gives:

$$\left[(\tau_p + \tau_s) \beta^2 + \left(1 + \frac{\tau_p}{\tau_{RC}} \right) \beta + \frac{1}{\tau_{RC}} \right] P e^{\beta t} + \frac{1}{\tau_{RC}} \left(Q - \frac{V_0}{R_{\Sigma p}} \right) = 0$$

For our guess to really be a solution, this last equation must hold true at any and all times t . Since the exponential term and the constant term depend on time in different ways, the only way this equation can hold true for any and all times t is if the two terms are separately equal to zero. In turn, this requires that the coefficients of the two terms be equal to zero. In other words, we must have:

$$\begin{aligned} (\tau_p + \tau_s) \beta^2 + \left(1 + \frac{\tau_p}{\tau_{RC}} \right) \beta + \frac{1}{\tau_{RC}} &= 0 \\ Q &= \frac{V_0}{R_{\Sigma p}} \end{aligned}$$

The equation in β is a quadratic, with the two roots β_{\pm} given by the quadratic formula:

$$\beta_{\pm} = \frac{-\left(1 + \frac{\tau_p}{\tau_{RC}}\right) \pm \sqrt{\left(1 + \frac{\tau_p}{\tau_{RC}}\right)^2 - 4\left(\frac{\tau_p + \tau_s}{\tau_{RC}}\right)}}{2(\tau_p + \tau_s)}$$

Each root represents a separate solution of the differential equation. Both solutions are valid and both must be included in the expression for i_p , each with its own coefficient. For convenience, we will call the two coefficients P_1 and P_2 . Incidentally, since this is a second order differential equation, there must be two and only two independent forms of solution. It seems that our guess encompassed them both. Therefore, we are able to say that the magnetizing current i_p is equal to:

$$i_p = P_1 e^{\frac{-\left(1 + \frac{\tau_p}{\tau_{RC}}\right) + \sqrt{\left(1 + \frac{\tau_p}{\tau_{RC}}\right)^2 - 4\left(\frac{\tau_p + \tau_s}{\tau_{RC}}\right)}}{2(\tau_p + \tau_s)} t} + P_2 e^{\frac{-\left(1 + \frac{\tau_p}{\tau_{RC}}\right) - \sqrt{\left(1 + \frac{\tau_p}{\tau_{RC}}\right)^2 - 4\left(\frac{\tau_p + \tau_s}{\tau_{RC}}\right)}}{2(\tau_p + \tau_s)} t} + \frac{V_0}{R_{\Sigma p}} \quad (3)$$

The two coefficients P_1 and P_2 will need to be found from the initial conditions. For now, let us set aside the determination of P_1 and P_2 and, instead, work on getting expressions for the other five circuit variables. Now that we have i_p , we can work our way through the circuit equations, finding each circuit variable in terms of ones found before. For convenience, we will not expand β_+ or β_- . We get:

$$\text{from Equation (3)} \quad i_p = P_1 e^{\beta_+ t} + P_2 e^{\beta_- t} + \frac{V_0}{R_{\Sigma p}} \quad (4A)$$

$$\text{from Equation (1C)} \quad v_p - v_{sw} = L_p (\beta_+ P_1 e^{\beta_+ t} + \beta_- P_2 e^{\beta_- t}) \quad (4B)$$

$$\text{from Equation (1D)} \quad v_s = \sqrt{L_p L_s} (\beta_+ P_1 e^{\beta_+ t} + \beta_- P_2 e^{\beta_- t}) \quad (4C)$$

$$\text{from Equation (1A'')} \quad i_s = -\sqrt{\frac{L_p}{L_s}} [(1 + \tau_p \beta_+) P_1 e^{\beta_+ t} + (1 + \tau_p \beta_-) P_2 e^{\beta_- t}] \quad (4D)$$

$$\text{from Equation (1A)} \quad i_p|_{total} = \frac{V_0}{R_{\Sigma p}} - \tau_p (\beta_+ P_1 e^{\beta_+ t} + \beta_- P_2 e^{\beta_- t}) \quad (4E)$$

$$\text{from Equation (1F)} \quad v_c = -\sqrt{\frac{L_p}{L_s}} \frac{1}{C_L} \left[\frac{(1 + \tau_p \beta_+)}{\beta_+} P_1 e^{\beta_+ t} + \frac{(1 + \tau_p \beta_-)}{\beta_-} P_2 e^{\beta_- t} \right] + P_3 \quad (4F)$$

Notice that the voltage v_c over the load capacitor is determined by integration, which leads to a third unknown constant P_3 , which will have to be found from a third initial condition.

Now, let's take a look at the initial conditions. This is best done by referring back to the schematic diagram. The magnetizing current i_p flowing through the primary winding is zero before switch S_1 closes. Since this magnetizing current flows through an inductor, it cannot change instantaneously. It will continue to be zero at the instant $t = 0$ immediately after switch S_1 closes. This means that:

$$\begin{aligned} \text{I. C. \#1} \quad i_p(t = 0) &= 0 \\ \rightarrow P_1 e^0 + P_2 e^0 + \frac{V_0}{R_{\Sigma p}} &= 0 \\ \rightarrow P_1 + P_2 &= -\frac{V_0}{R_{\Sigma p}} \quad (5A) \end{aligned}$$

That takes care of one initial condition. The other is found using the voltage over the load capacitor. The voltage v_c over the capacitor is $v_c|_0$ before switch S_1 closes and it, being the voltage over a capacitor, cannot change instantaneously. This means that:

$$\begin{aligned}
I.C. \#2 \quad & v_c(t = 0) = v_c|_0 \\
\rightarrow & -\sqrt{\frac{L_p}{L_s C_L}} \left[\frac{(1 + \tau_p \beta_+)}{\beta_+} P_1 e^0 + \frac{(1 + \tau_p \beta_-)}{\beta_-} P_2 e^0 \right] + P_3 = v_c|_0 \\
\rightarrow & -\sqrt{\frac{L_p}{L_s C_L}} \left[\frac{(1 + \tau_p \beta_+)}{\beta_+} P_1 + \frac{(1 + \tau_p \beta_-)}{\beta_-} P_2 \right] + P_3 = v_c|_0 \quad (5B)
\end{aligned}$$

The third initial condition is a little bit trickier to see. Although the magnetizing current i_p flowing through the primary winding will be zero immediately after switch S_1 closes, it is only one of the two currents flowing through the primary winding. The other current is proportional to the current flowing in the secondary circuit, and is the source of the energy being transferred from the primary circuit into the secondary circuit. Energy will be transferred from the primary side to the secondary side right from the get-go. As always, the ratio of voltages over the ideal inductances will be equal to the turns-ratio, as expressed in Equation (1D). There must be a balance between the non-magnetizing currents flowing in the primary and secondary windings which is consistent with this voltage ratio. This will involve current $i_p|_{total}$ on the primary side and current i_s on the secondary side. Taking the sum of the voltage drops around the primary circuit at time $t = 0$, immediately after switch S_1 closes, gives:

$$\begin{aligned}
(v_p - v_{sw})|_0 &= V_0 - R_{\Sigma p} i_p|_{total}(t = 0) \\
&= V_0 - R_{\Sigma p} \left[\frac{V_0}{R_{\Sigma p}} - \tau_p (\beta_+ P_1 e^0 + \beta_- P_2 e^0) \right] \\
&= R_{\Sigma p} \tau_p (\beta_+ P_1 + \beta_- P_2) \\
&= L_p (\beta_+ P_1 + \beta_- P_2)
\end{aligned}$$

Taking the sum of the voltage drops around the secondary circuit at time $t = 0$, immediately after switch S_1 closes, gives:

$$\begin{aligned}
v_s|_0 &= (R_s + R_{esr}) i_s(t = 0) + V_d + v_c|_0 \\
&= -(R_s + R_{esr}) \sqrt{\frac{L_p}{L_s}} \left[(1 + \tau_p \beta_+) P_1 e^0 + (1 + \tau_p \beta_-) P_2 e^0 \right] + V_d + v_c|_0 \\
&= -(R_s + R_{esr}) \sqrt{\frac{L_p}{L_s}} \left[(1 + \tau_p \beta_+) P_1 + (1 + \tau_p \beta_-) P_2 \right] + V_d + v_c|_0
\end{aligned}$$

These voltage drops, over the ideal primary and secondary windings, are related by the turn-ratio:

$$v_s|_0 = \frac{N_s}{N_p} (v_p - v_{sw})|_0 = \sqrt{\frac{L_s}{L_p}} (v_p - v_{sw})|_0$$

Substituting the expressions from the two previous equations gives:

$$\begin{aligned}
& -(R_s + R_{esr}) \sqrt{\frac{L_p}{L_s}} [(1 + \tau_p \beta_+) P_1 + (1 + \tau_p \beta_-) P_2] + V_d + v_c|_0 = \sqrt{\frac{L_s}{L_p}} L_p (\beta_+ P_1 + \beta_- P_2) \\
\rightarrow & -\frac{1}{\tau_s} [(1 + \tau_p \beta_+) P_1 + (1 + \tau_p \beta_-) P_2] + \frac{V_d + v_c|_0}{\sqrt{L_p L_s}} = \beta_+ P_1 + \beta_- P_2 \\
\rightarrow & (1 + \tau_p \beta_+ + \tau_s \beta_+) P_1 + (1 + \tau_p \beta_- + \tau_s \beta_-) P_2 = \frac{\tau_s (V_d + v_c|_0)}{\sqrt{L_p L_s}} \quad (5C)
\end{aligned}$$

The three initial conditions have been expressed in the three Equations (5A) through (5C), which can now be solved for the three unknown (constant) coefficients P_1 , P_2 and P_3 . The solutions for P_1 and P_2 are:

$$P_1 = -\frac{\frac{\tau_s (V_d + v_c|_0)}{\sqrt{L_p L_s}} + [1 + \beta_- (\tau_p + \tau_s)] \frac{V_0}{R_{\Sigma p}}}{(\tau_p + \tau_s) (\beta_+ - \beta_-)} \quad (6A)$$

$$P_2 = -\frac{\frac{\tau_s (V_d + v_c|_0)}{\sqrt{L_p L_s}} + [1 + \beta_+ (\tau_p + \tau_s)] \frac{V_0}{R_{\Sigma p}}}{(\tau_p + \tau_s) (\beta_+ - \beta_-)} \quad (6B)$$

I have not troubled to expand P_3 at this time.

We can make a simplifying assumption based on the relative values of the time-constants. These relative values are driven by the two principal characteristics of this type of charging circuit: (i) that the secondary inductance is much larger than the primary inductance and (ii) that the load capacitance is relatively large. To see this, one can evaluate the three time-constants defined above using our component values:

$$\begin{aligned}
\tau_p &= \frac{L_p}{(R_{cl} + R_p + R_{ON})} = \frac{91.1 \mu}{6 + 0.1 + 0.03} = 14.9 \mu\text{s} \\
\tau_{RC} &= (R_s + R_{esr}) C_L = (26.2 + 2) 100 \mu = 2.82 \text{ms} \gg \tau_p \\
\tau_s &= \frac{L_s}{(R_s + R_{esr})} = \frac{11.2}{26.2 + 2} = 397 \text{ms} \gg \tau_{RC}
\end{aligned}$$

These inequalities are very general and will almost certainly obtain for any circuit of this type:

$$\tau_s \gg \tau_{RC} \gg \tau_p \quad (7)$$

Let us begin by applying these inequalities to the frequencies β_+ and β_- .

$$\begin{aligned}
\beta_{\pm} &\cong \frac{-\left(1 + \frac{\tau_p}{\tau_{RC}}\right) \pm \sqrt{\left(1 + \frac{\tau_p}{\tau_{RC}}\right)^2 - 4 \left(\frac{\tau_p + \tau_s}{\tau_{RC}}\right)}}{2(\tau_p + \tau_s)} \\
&= \frac{-1 \pm \sqrt{1 - 4 \left(\frac{\tau_s}{\tau_{RC}}\right)}}{2\tau_s}
\end{aligned}$$

We are not yet finished approximating:

$$\begin{aligned}
\beta_{\pm} &\cong \frac{-1 \pm \sqrt{1 - 4 \left(\frac{\tau_s}{\tau_{RC}} \right)}}{2\tau_s} \\
&= \frac{-1 \pm 2j \sqrt{\frac{\tau_s}{\tau_{RC}}}}{2\tau_s} \\
&= -\frac{1}{2\tau_s} \pm j \frac{1}{\sqrt{\tau_s \tau_{RC}}} \quad (8)
\end{aligned}$$

These two roots have the following implications for the waveform of i_p . i_p will be linear combination of sinusoidal terms having an angular frequency of $1/\sqrt{\tau_s \tau_{RC}}$, whose amplitudes decrease exponentially with a time-constant of $2\tau_s$.

Let us substitute these simplified forms for β_+ and β_- into our expressions for P_1 and P_2 . For the time being, we will not worry about P_3 . For P_1 , we get:

$$\begin{aligned}
P_1 &= \frac{\frac{\tau_s(V_d + v_c|_0)}{\sqrt{L_p L_s}} + [1 + \beta_- (\tau_{\overline{p}} + \tau_s)] \frac{V_0}{R_{\Sigma p}}}{(\tau_{\overline{p}} + \tau_s)(\beta_+ - \beta_-)} \\
&\cong \frac{\frac{V_d + v_c|_0}{\sqrt{L_p L_s}} + \left(\frac{1}{\tau_s} + \beta_- \right) \frac{V_0}{R_{\Sigma p}}}{(\beta_+ - \beta_-)} \\
&= \frac{\frac{V_d + v_c|_0}{\sqrt{L_p L_s}} + \left(\frac{1}{2\tau_s} - j \frac{1}{\sqrt{\tau_s \tau_{RC}}} \right) \frac{V_0}{R_{\Sigma p}}}{j \frac{2}{\sqrt{\tau_s \tau_{RC}}}} \\
&= -\frac{j}{2} \left[\frac{\sqrt{\tau_s \tau_{RC}} (V_d + v_c|_0)}{\sqrt{L_p L_s}} + \left(\frac{1}{2} \sqrt{\frac{\tau_{RC}}{\tau_s}} - j \right) \frac{V_0}{R_{\Sigma p}} \right] \\
&= -\frac{j}{2} \left[\sqrt{\frac{C_L}{L_p}} (V_d + v_c|_0) + \frac{1}{2} \sqrt{\frac{\tau_{RC}}{\tau_s}} \frac{V_0}{R_{\Sigma p}} \right] - \frac{1}{2} \frac{V_0}{R_{\Sigma p}} \quad (9A)
\end{aligned}$$

Similarly, for P_2 , we get:

$$\begin{aligned}
P_2 &= -\frac{\frac{\tau_s(V_d + v_c|_0)}{\sqrt{L_p L_s}} + [1 + \beta_+ (\tau_{\overline{p}} + \tau_s)] \frac{V_0}{R_{\Sigma p}}}{(\tau_{\overline{p}} + \tau_s)(\beta_+ - \beta_-)} \\
&\cong -\frac{\frac{V_d + v_c|_0}{\sqrt{L_p L_s}} + \left(\frac{1}{\tau_s} + \beta_+ \right) \frac{V_0}{R_{\Sigma p}}}{(\beta_+ - \beta_-)}
\end{aligned}$$

And, continuing:

$$\begin{aligned}
P_2 &= -\frac{\frac{V_d + v_c|_0}{\sqrt{L_p L_s}} + \left(\frac{1}{2\tau_s} + j\frac{1}{\sqrt{\tau_s \tau_{RC}}}\right) \frac{V_0}{R_{\Sigma p}}}{j\frac{2}{\sqrt{\tau_s \tau_{RC}}}} \\
&= \frac{j}{2} \left[\frac{\sqrt{\tau_s \tau_{RC}} (V_d + v_c|_0)}{\sqrt{L_p L_s}} + \left(\frac{1}{2} \sqrt{\frac{\tau_{RC}}{\tau_s}} + j\right) \frac{V_0}{R_{\Sigma p}} \right] \\
&= \frac{j}{2} \left[\sqrt{\frac{C_L}{L_p}} (V_d + v_c|_0) + \frac{1}{2} \sqrt{\frac{\tau_{RC}}{\tau_s}} \frac{V_0}{R_{\Sigma p}} \right] - \frac{1}{2} \frac{V_0}{R_{\Sigma p}} \quad (9B)
\end{aligned}$$

Now, let us make another simplifying assumption. Let us assume that the times t of interest are very small. If $\beta_+ t$ and $\beta_- t$ are small, we can use the Taylor series expansion and approximation for the exponential function, that $e^x \cong 1 + x$ for small x . Then, we can approximate as follows:

$$e^{\beta_+ t} \cong 1 + \beta_+ t \quad (10A)$$

$$e^{\beta_- t} \cong 1 + \beta_- t \quad (10B)$$

Next, we are going to expand the expressions for the circuit variables, substituting P_1 and P_2 , and using the two sets of approximations. As you will see, two particular combinations of the constants P_1 and P_2 and the roots β_+ and β_- arise frequently, and it helps to expand and approximate them first:

$$\begin{aligned}
\beta_+ P_1 + \beta_- P_2 &\cong \left(-\frac{1}{2\tau_s} + j\frac{1}{\sqrt{\tau_s \tau_{RC}}}\right) P_1 + \left(-\frac{1}{2\tau_s} - j\frac{1}{\sqrt{\tau_s \tau_{RC}}}\right) P_2 \\
&= -\frac{1}{2\tau_s} (P_1 + P_2) + j\frac{1}{\sqrt{\tau_s \tau_{RC}}} (P_1 - P_2) \\
&\cong -\frac{1}{2\tau_s} \left(-\frac{V_0}{R_{\Sigma p}}\right) + j\frac{1}{\sqrt{\tau_s \tau_{RC}}} \left\{ -j \left[\sqrt{\frac{C_L}{L_p}} (V_d + v_c|_0) + \frac{1}{2} \sqrt{\frac{\tau_{RC}}{\tau_s}} \frac{V_0}{R_{\Sigma p}} \right] \right\} \\
&= \frac{1}{2\tau_s} \frac{V_0}{R_{\Sigma p}} + \frac{1}{\sqrt{\tau_s \tau_{RC}}} \sqrt{\frac{C_L}{L_p}} (V_d + v_c|_0) + \frac{1}{2\tau_s} \frac{V_0}{R_{\Sigma p}} \\
&= \left(\frac{V_d + v_c|_0}{\sqrt{L_p L_s}}\right) + \frac{1}{\tau_s} \frac{V_0}{R_{\Sigma p}} \quad (11A)
\end{aligned}$$

and

$$\begin{aligned}
\beta_+^2 P_1 + \beta_-^2 P_2 &\cong \left(-\frac{1}{2\tau_s} + j\frac{1}{\sqrt{\tau_s \tau_{RC}}}\right)^2 P_1 + \left(-\frac{1}{2\tau_s} - j\frac{1}{\sqrt{\tau_s \tau_{RC}}}\right)^2 P_2 \\
&= \left(\frac{1}{4\tau_s^2} - j\frac{1}{\tau_s \sqrt{\tau_s \tau_{RC}}} - \frac{1}{\tau_s \tau_{RC}}\right) P_1 + \left(\frac{1}{4\tau_s^2} + j\frac{1}{\tau_s \sqrt{\tau_s \tau_{RC}}} - \frac{1}{\tau_s \tau_{RC}}\right) P_2 \\
&= \left(\frac{1}{4\tau_s^2} - \frac{1}{\tau_s \tau_{RC}}\right) (P_1 + P_2) - j\frac{1}{\tau_s \sqrt{\tau_s \tau_{RC}}} (P_1 - P_2)
\end{aligned}$$

And, continuing:

$$\begin{aligned}
\beta_+^2 P_1 + \beta_-^2 P_2 &\cong \left(\frac{1}{4\tau_s^2} - \frac{1}{\tau_s \tau_{RC}} \right) \left(-\frac{V_0}{R_{\Sigma p}} \right) - j \frac{1}{\tau_s \sqrt{\tau_s \tau_{RC}}} \left\{ -j \left[\sqrt{\frac{C_L}{L_p}} (V_d + v_c|_0) + \frac{1}{2} \sqrt{\frac{\tau_{RC}}{\tau_s}} \frac{V_0}{R_{\Sigma p}} \right] \right\} \\
&= - \left(\frac{1}{4\tau_s^2} - \frac{1}{\tau_s \tau_{RC}} \right) \frac{V_0}{R_{\Sigma p}} - \frac{1}{\tau_s} \left[\left(\frac{V_d + v_c|_0}{\sqrt{L_p L_s}} \right) + \frac{1}{2\tau_s} \frac{V_0}{R_{\Sigma p}} \right] \\
&= - \frac{1}{\tau_s} \left(\frac{V_d + v_c|_0}{\sqrt{L_p L_s}} \right) + \frac{1}{\tau_s \tau_{RC}} \left(1 - \frac{3\tau_{RC}}{4\tau_s} \right) \frac{V_0}{R_{\Sigma p}} \\
&\cong - \frac{1}{\tau_s} \left(\frac{V_d + v_c|_0}{\sqrt{L_p L_s}} \right) + \frac{1}{\tau_s \tau_{RC}} \frac{V_0}{R_{\Sigma p}} \\
&= \frac{1}{\tau_s} \left[- \left(\frac{V_d + v_c|_0}{\sqrt{L_p L_s}} \right) + \frac{1}{\tau_{RC}} \frac{V_0}{R_{\Sigma p}} \right] \tag{11B}
\end{aligned}$$

The circuit variable $v_p - v_{sw}$ can be expanded as:

$$\begin{aligned}
v_p - v_{sw} &= L_p (\beta_+ P_1 e^{\beta_+ t} + \beta_- P_2 e^{\beta_- t}) \\
&\cong L_p [\beta_+ P_1 (1 + \beta_+ t) + \beta_- P_2 (1 + \beta_- t)] \\
&= L_p (\beta_+ P_1 + \beta_- P_2) + L_p (\beta_+^2 P_1 + \beta_-^2 P_2) t \\
&\cong L_p \left[\left(\frac{V_d + v_c|_0}{\sqrt{L_p L_s}} \right) + \frac{1}{\tau_s} \frac{V_0}{R_{\Sigma p}} \right] + \frac{L_p}{\tau_s} \left[- \left(\frac{V_d + v_c|_0}{\sqrt{L_p L_s}} \right) + \frac{1}{\tau_{RC}} \frac{V_0}{R_{\Sigma p}} \right] t \\
&= \left[\sqrt{\frac{L_p}{L_s}} (V_d + v_c|_0) + \frac{\tau_p}{\tau_s} V_0 \right] - \frac{1}{\tau_s} \left[\sqrt{\frac{L_p}{L_s}} (V_d + v_c|_0) - \frac{\tau_p}{\tau_{RC}} V_0 \right] t \tag{12A}
\end{aligned}$$

The circuit variable $i_p|_{total}$ can be expanded as:

$$\begin{aligned}
i_p|_{total} &\cong \frac{V_0}{R_{\Sigma p}} - \tau_p [\beta_+ P_1 (1 + \beta_+ t) + \beta_- P_2 (1 + \beta_- t)] \\
&= \frac{V_0}{R_{\Sigma p}} - \tau_p [(\beta_+ P_1 + \beta_- P_2) + (\beta_+^2 P_1 + \beta_-^2 P_2) t] \\
&= \frac{V_0}{R_{\Sigma p}} - \tau_p \left[\left(\frac{V_d + v_c|_0}{\sqrt{L_p L_s}} \right) + \frac{1}{\tau_s} \frac{V_0}{R_{\Sigma p}} \right] - \frac{\tau_p}{\tau_s} \left[- \left(\frac{V_d + v_c|_0}{\sqrt{L_p L_s}} \right) + \frac{1}{\tau_{RC}} \frac{V_0}{R_{\Sigma p}} \right] t \\
&\cong \left[\left(1 - \frac{\tau_p}{\tau_s} \right) \frac{V_0}{R_{\Sigma p}} - \tau_p \left(\frac{V_d + v_c|_0}{\sqrt{L_p L_s}} \right) \right] + \frac{1}{\tau_s} \left[\sqrt{\frac{L_p}{L_s}} (V_d + v_c|_0) - \frac{\tau_p}{\tau_{RC}} V_0 \right] t \\
&\cong \left[\frac{V_0}{R_{\Sigma p}} - \sqrt{\frac{L_p}{L_s}} \left(\frac{V_d + v_c|_0}{R_{\Sigma p}} \right) \right] + \frac{1}{\tau_s} \left[\sqrt{\frac{L_p}{L_s}} (V_d + v_c|_0) - \frac{\tau_p}{\tau_{RC}} V_0 \right] t \tag{12B}
\end{aligned}$$

We will skip the circuit variable v_s , which is just a multiple of $v_p - v_{sw}$. Then, the circuit variable i_s can be expanded as:

$$\begin{aligned}
i_s &= -\sqrt{\frac{L_p}{L_s}} \left[(1 + \tau_p \beta_+) P_1 e^{\beta_+ t} + (1 + \tau_p \beta_-) P_2 e^{\beta_- t} \right] \\
&\cong -\sqrt{\frac{L_p}{L_s}} \left[(1 + \tau_p \beta_+) P_1 (1 + \beta_+ t) + (1 + \tau_p \beta_-) P_2 (1 + \beta_- t) \right] \\
&= -\sqrt{\frac{L_p}{L_s}} \left[(P_1 + P_2) + \tau_p (\beta_+ P_1 + \beta_- P_2) + (\beta_+ P_1 + \beta_- P_2) t + \tau_p (\beta_+^2 P_1 + \beta_-^2 P_2) t \right] \\
&\cong -\sqrt{\frac{L_p}{L_s}} \left\{ \begin{aligned} &-\frac{V_0}{R_{\Sigma p}} + \tau_p \left[\left(\frac{V_d + v_c |_0}{\sqrt{L_p L_s}} \right) + \frac{1}{\tau_s} \frac{V_0}{R_{\Sigma p}} \right] + \dots \\ &\dots + \left[\left(\frac{V_d + v_c |_0}{\sqrt{L_p L_s}} \right) + \frac{1}{\tau_s} \frac{V_0}{R_{\Sigma p}} \right] t + \tau_p \left[\frac{1}{\tau_s} \left[- \left(\frac{V_d + v_c |_0}{\sqrt{L_p L_s}} \right) + \frac{1}{\tau_{RC}} \frac{V_0}{R_{\Sigma p}} \right] \right] t \end{aligned} \right\}
\end{aligned}$$

Terms can be collected to give:

$$\begin{aligned}
i_s &= -\sqrt{\frac{L_p}{L_s}} \left\{ \begin{aligned} &\tau_p \left(\frac{V_d + v_c |_0}{\sqrt{L_p L_s}} \right) + \left(-1 + \frac{\tau_p}{\tau_s} \right) \frac{V_0}{R_{\Sigma p}} + \dots \\ &\dots + \left[\left(1 - \frac{\tau_p}{\tau_s} \right) \left(\frac{V_d + v_c |_0}{\sqrt{L_p L_s}} \right) + \frac{1}{\tau_s} \left(1 + \frac{\tau_p}{\tau_{RC}} \right) \frac{V_0}{R_{\Sigma p}} \right] t \end{aligned} \right\} \\
&\cong -\sqrt{\frac{L_p}{L_s}} \left\{ \left[\tau_p \left(\frac{V_d + v_c |_0}{\sqrt{L_p L_s}} \right) - \frac{V_0}{R_{\Sigma p}} \right] + \left[\left(\frac{V_d + v_c |_0}{\sqrt{L_p L_s}} \right) + \frac{1}{\tau_s} \frac{V_0}{R_{\Sigma p}} \right] t \right\} \\
&= \sqrt{\frac{L_p}{L_s}} \left\{ \left[\frac{V_0}{R_{\Sigma p}} - \sqrt{\frac{L_p}{L_s}} \left(\frac{V_d + v_c |_0}{R_{\Sigma p}} \right) \right] - \left[\left(\frac{V_d + v_c |_0}{\sqrt{L_p L_s}} \right) + \frac{1}{\tau_s} \frac{V_0}{R_{\Sigma p}} \right] t \right\} \quad (12C)
\end{aligned}$$

All of the circuit variables have now been expressed as linear relationships with time, that is, in the form $A + Bt$. Let us look at the secondary current i_s . Equation (12C) shows two things:

- That i_s is initially approximately equal to $\sqrt{L_p/L_s} V_0/R_{\Sigma p}$. Remember that the turns-ratio is very large so that the factor $\sqrt{L_p/L_s}$ is very small. This causes the second term inside the first set of square brackets to be very small compared with the first term, $V_0/R_{\Sigma p}$.
- That i_s decreases thereafter linearly with time. This arises because of the minus sign in front of the coefficient of time t .

These two observations have two consequences: (i) that i_s is initially positive, which means that current flows through diode D_1 in the positive direction, in its conduction mode, and (ii) that at some point in time, the secondary current will fall to zero.

We can calculate the time $t = T_{stop}$ at which the secondary current reaches zero. This is the moment when diode D_1 will stop conducting. Mathematically, this will happen when the expression in Equation (12C) reaches zero. Setting Equation (12C) equal to zero at time $t = T_{stop}$ gives:

$$T_{stop} = \frac{\frac{V_0}{R_{\Sigma p}} - \sqrt{\frac{L_p}{L_s} \left(\frac{V_d + v_c|_0}{R_{\Sigma p}} \right)}}{\left(\frac{V_d + v_c|_0}{\sqrt{L_p L_s}} \right) + \frac{1}{\tau_s} \frac{V_0}{R_{\Sigma p}}} \quad (13)$$

How does the duration of the conduction period vary with the initial voltage over the load capacitor? Using our component values, Equation (13) becomes:

$$\begin{aligned} T_{stop} &= \frac{\frac{12}{6.13} - \sqrt{\frac{91.1\mu}{11.2} \left(\frac{5.8 + v_c|_0}{6.13} \right)}}{\left(\frac{5.8 + v_c|_0}{\sqrt{91.1\mu \times 11.2}} \right) + \frac{1}{0.397} \left(\frac{12}{6.13} \right)} \\ &= \frac{1.955 - 0.0004653v_c|_0}{186.5 + 31.31v_c|_0} \end{aligned}$$

T_{stop} will be a positive time for all initial capacitor voltages up to $v_c|_0 = 1.955/0.0004653 = 4202V$. In other words, the charging circuit should charge up until this point. (Remember that we added a few more turns to the secondary winding than was needed to arrive exactly at the target voltage 4000V.)

Let us calculate two or three sample values. When the initial load capacitor voltage is zero, the cut-off time will be $T_{stop} = 1.955/186.5 = 10.48ms$. When the initial capacitor voltage is 500V, the cut-off time will be $T_{stop} = 1.722/15,840 = 108.7\mu s$. And, when the initial capacitor voltage is 3000V, the cut-off time will be $T_{stop} = 0.5591/94,120 = 5.941\mu s$.

We should not lose sight of the fact that our ferrite core works best at cycling periods in the range from $2.5\mu s$ to $100\mu s$. Without considering other factors, such as the time needed to “reset” the current for the following charge cycle, $T_{stop} = 100\mu s$ is not reached until $v_c|_0 = 538V$. In other words, when the initial voltage over the load capacitor is less than 538V, a complete “charging cycle” takes longer than $100\mu s$, which corresponds to a frequency of 10KHz. At the other extreme, $T_{stop} = 2.5\mu s$ is reached when the load capacitor’s initial voltage is $v_c|_0 = 3596V$. At initial voltages higher than 3596V, a complete “charging cycle” takes less than $2.5\mu s$, which corresponds to a frequency of 400KHz. It seems that, at low voltages and at high voltages, the length of a complete “charging cycle” is such that it falls outside of the range of frequencies at which the material of the transformer’s core operates most efficiently.

For the sake of clarity, I want to explain why the phrase “charging cycle” was put in quotation marks in the preceding paragraph. The “charging cycle” referred to is not the cycle by which the load capacitor is charged up from zero to its target voltage of 4000V. Far from it. Instead, one “charging cycle” is the time during which the current flowing in the primary circuit rises from zero to its maximum value, $2A$. Once that happens, or even before, no more energy is transferred into the load capacitor, which is another way of saying that current stops flowing in the secondary circuit. It will be necessary, somehow, to reset the primary circuit to zero current before starting another “charging cycle”. During each “charging cycle”, a little more energy/voltage is added to the load capacitor. A great number of “charging cycles” will be needed to charge the load capacitor up to the desired energy/voltage.

It is useful to evaluate the expressions for the circuit variables using our component values, but leaving the initial capacitor voltage $v_c|_0$ as a variable.

For $v_p - v_{sw}$, the voltage drop over the transformer's primary winding, Equation (12A) becomes:

$$v_p - v_{sw} \cong \left\{ \begin{array}{l} \left[\sqrt{\frac{91.1\mu}{11.2}} (5.8 + v_c|_0) + \left(\frac{14.9\mu}{0.397}\right) 12 \right] + \dots \\ \dots - \frac{1}{0.397} \left[\sqrt{\frac{91.1\mu}{11.2}} (5.8 + v_c|_0) - \left(\frac{14.9\mu}{0.00282}\right) 12 \right] t \end{array} \right\}$$

$$= (0.01699 + 0.002852v_c|_0) + (0.1180 - 0.007184v_c|_0)t$$

For $i_p|_{total}$, the total current flowing in the primary circuit, Equation (12B) becomes:

$$i_p|_{total} \cong \left\{ \begin{array}{l} \left[\frac{12}{6.13} - \sqrt{\frac{91.1\mu}{11.2}} \left(\frac{5.8 + v_c|_0}{6.13}\right) \right] + \dots \\ \dots + \frac{1}{0.397} \left[\sqrt{\frac{91.1\mu}{11.2}} (5.8 + v_c|_0) - \left(\frac{14.9\mu}{0.00282}\right) 12 \right] t \end{array} \right\}$$

$$= (1.955 - 0.0004653v_c|_0) + (-0.1180 + 0.007184v_c|_0)t$$

For i_s , the current flowing in the secondary circuit when diode D_1 conducts, Equation (12C) becomes:

$$i_s \cong \sqrt{\frac{91.1\mu}{11.2}} \left\{ \begin{array}{l} \left[\frac{12}{6.13} - \sqrt{\frac{91.1\mu}{11.2}} \left(\frac{5.8 + v_c|_0}{6.13}\right) \right] + \dots \\ \dots - \left[\frac{5.8 + v_c|_0}{\sqrt{91.1\mu \times 11.2}} + \frac{1}{0.397} \frac{12}{6.13} \right] t \end{array} \right\}$$

$$= (0.005575 - 0.000001327v_c|_0) - (0.5319 + 0.08929v_c|_0)t$$

Let us evaluate these expressions at three different initial voltages over the load capacitor: 0V, 500V and 3000V. All quantities have been expressed in SI units which, in the current context, means Volts and seconds.

$v_c _0 \rightarrow$	0V	500V	3000V
$v_p - v_{sw} =$	$0.01699 + 0.1180t$	$1.443 - 3.474t$	$8.573 - 21.43t$
$i_p _{total} =$	$1.955 - 0.1180t$	$1.722 + 3.474t$	$0.5591 + 21.43t$
$i_s =$	$0.005575 - 0.5319t$	$0.004912 - 45.18t$	$0.001594 - 268.4t$

Now, let us take just one more step. Let us evaluate these three circuit variables at time $t = 0$, when the charging cycle starts, and at the T_{stop} , when the charging cycle stops, for the three initial voltages over the load capacitor.

$v_c _0 \rightarrow$	0V	0V	500V	500V	3000V	3000V
$t =$	0	$T_{stop} = 10.48\text{ms}$	0	$T_{stop} = 108.7\mu\text{s}$	0	$T_{stop} = 5.941\mu\text{s}$
$v_p - v_{sw} =$	16.99mV	18.23mV	1.443V	1.443V	8.573V	8.573V
$i_p _{total} =$	1.955A	1.954A	1.722A	1.722A	0.5591A	0.5592A
$i_s =$	5.575mA	0	4.912mA	0	1.594mA	0

Observations:

- Except for very low initial capacitor voltages, the voltage drop over the ideal primary inductance remains pretty constant throughout a single charging cycle.
- The total primary current $i_p|_{total}$ also remains constant throughout a single charging cycle, although it decreases very slightly when the initial capacitor voltage is low and increases very slightly when the initial capacitor voltage is high.
- As described above, the secondary current decreases to zero at time T_{stop} . (Indeed, that event defines time T_{stop} .)

To examine the accuracy of the circuit equations and the appropriateness of the approximations made, the SPICE model was run three times, once for each of the three initial voltages over the load capacitor. The following graphs show the results obtained. In each graph, three circuit variables are shown:

- the voltage drop $v_p - v_{sw}$ over the ideal primary inductance. The corresponding SPICE parameter names are V(vp)-V(vsw) and the trace is shown in red;
- the total current $i_p|_{total}$ flowing in the primary circuit. The current through resistor R_p , which is the SPICE variable I(Rp), is used as a proxy for $i_p|_{total}$ and is shown in blue; and
- the current i_s flowing in the secondary circuit. The current through resistor R_s , which is the SPICE parameter I(Rs), is shown in gray. Note that its value is multiplied by 1000.

The left vertical axis is the measure of voltage and the right vertical axis is the measure of current.

For the uncharged load capacitor, the SPICE waveforms are:

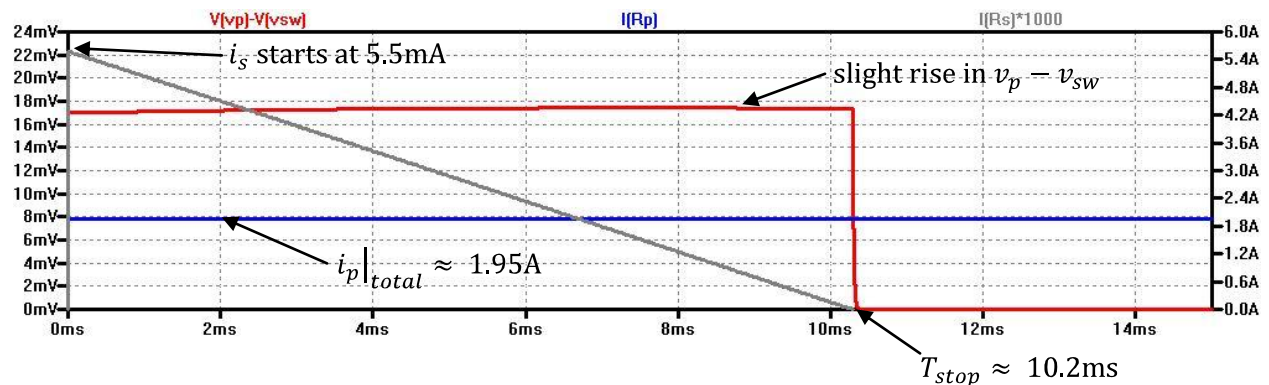

When the load capacitor is initially charged to 500V, the SPICE waveforms are:

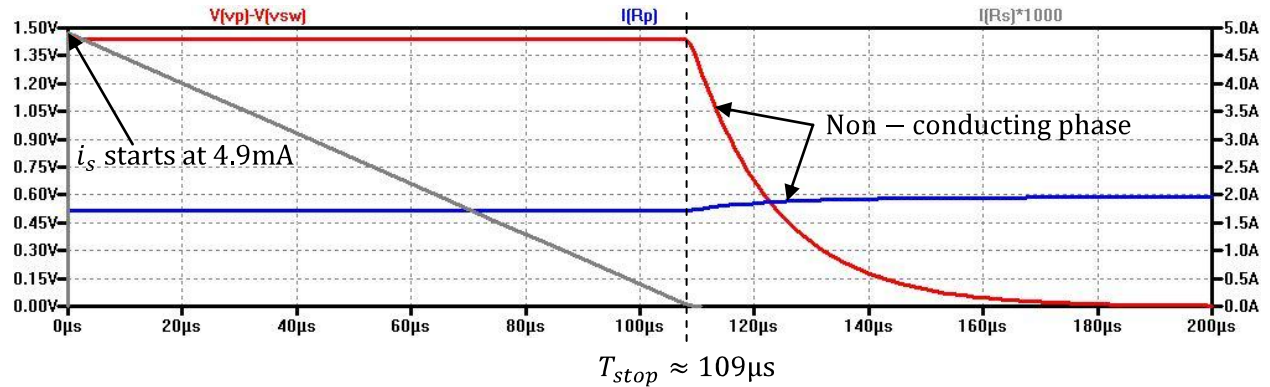

When the load capacitor is initially charged to 3000V, the SPICE waveforms are:

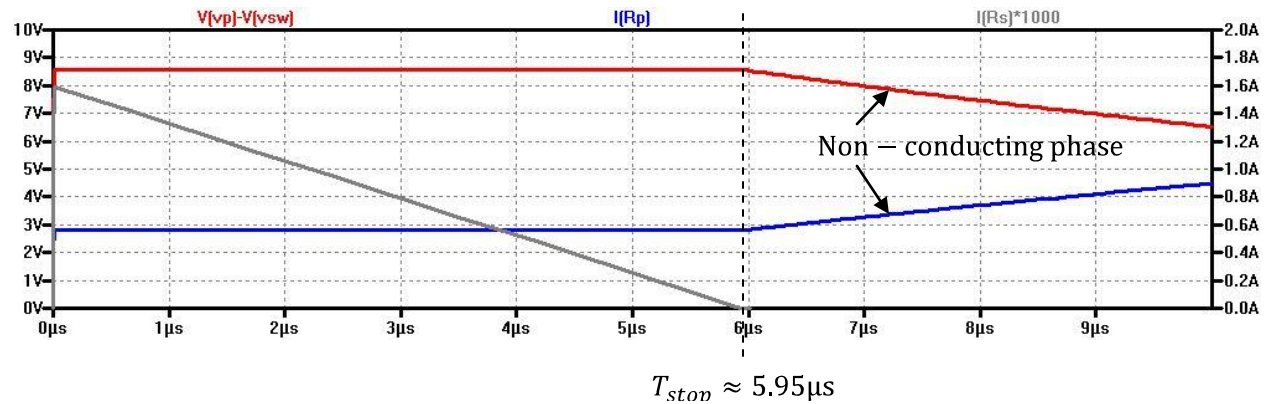

Our mathematical analysis agrees remarkably well with the SPICE simulation.

Part #1B – A single charging cycle, when diode D_1 is NOT conducting

The waveforms above give some idea about what happens once diode D_1 stops conducting. A “non-conducting” phase in a “charging cycle” is a bit of a misnomer, but it happens anyway. When diode D_1 stops conducting, the circuit is not in a steady-state. Let us see what happens. When we developed the circuit equations above, we reached a point where we had two equations for the secondary current i_s . The conducting phase we looked at in the previous section was one branch, characterized by current flowing through diode D_1 . In this section, we will take the second branch, in which diode D_1 is reverse-biased. We will resume the mathematical analysis with the circuit equations at the point where we branched before. When we left off, we had the following equations for the non-conducting phase of the charging cycle.

$$V_0 = R_{\Sigma p} \left(i_p + \sqrt{\frac{L_s}{L_p}} i_s \right) + L_p \frac{di_p}{dt} \quad (1A')$$

$$\frac{dv_s}{dt} = \sqrt{L_p L_s} \frac{d^2 i_p}{dt^2} \quad (1D')$$

$$i_s = 0 \quad (1Eb' - \text{not conducting})$$

Substituting $i_s = 0$ into Equation (1A') gives, immediately, a first-order differential equation in the single variable i_p , which is the magnetizing current through the primary winding:

$$L_p \frac{di_p}{dt} + R_{\Sigma p} i_p = V_0 \quad (1A''')$$

Using the time-constants we previously defined, this can be written as:

$$\tau_p \frac{di_p}{dt} + i_p = \frac{V_0}{R_{\Sigma p}} \quad (14)$$

We can guess that the general form of solution will be $i_p = X e^{\alpha t} + Y$. Substitution gives:

$$\tau_p X \alpha e^{\alpha t} + X e^{\alpha t} + Y = \frac{V_0}{R_{\Sigma p}}$$

Collecting terms gives:

$$(\tau_p \alpha + 1) X e^{\alpha t} + \left(Y - \frac{V_0}{R_{\Sigma p}} \right) = 0$$

For our guess to really be a solution, this last equation must hold true for any and all times t . Since the exponential term and the constant term depend on times in different ways, the only way this equation can hold true for any and all times t is if the two terms are separately equal to zero. In turn, this requires that the coefficients of the two terms be equal to zero. Therefore, we must have:

$$\begin{aligned} \tau_p \alpha + 1 &= 0 \\ Y &= \frac{V_0}{R_{\Sigma p}} \end{aligned}$$

The root of the first equation is $\alpha = -1/\tau_p$, so i_p will have the following waveform:

$$i_p = X e^{-\frac{t}{\tau_p}} + \frac{V_0}{R_{\Sigma p}} \quad (15)$$

This is a good deal simpler than the corresponding equation for the conducting phase of a charging cycle. There is a good reason why. After diode D_1 stops conducting, no more current flows in the secondary circuit. In effect, the secondary circuit ceases to exist from the point-of-view of the primary circuit. The primary circuit will carry on under the influence of its self-inductance L_p only, hence the absence of any dependence on the components in the secondary circuit.

It is not really necessary for us to enquire into the initial conditions. The initial conditions for the non-conducting phase will be the circuit conditions when the conducting phase ended, at time $t = T_{stop}$.

Of more interest is the “ending” condition of the non-conducting phase. The ending condition will be the steady-state. As time passes, the first term in Equation (15) will die out, leaving the steady-state current $V_0/R_{\Sigma p}$. As expected, the steady-state current is determined by the supply voltage V_0 and the series resistance $R_{\Sigma p}$ in the primary circuit. In our circuit, this will be very close to 2A.

The time-constant τ_p determines how quickly the non-conducting phase will reach the steady-state condition. Using our component values, we can evaluate τ_p , as we did above, to get $\tau_p = 14.9\mu\text{s}$.

Although the time-constant τ_p does not depend on the load capacitor's initial voltage, the actual length of time that will be needed to reach the steady-state condition does. The higher the capacitor's initial voltage, the lower the primary current will be during the conducting phase. Then, when the conducting phase ends, the longer it will take for the primary current to increase to its steady-state value. A glance at the graphs above, for times after T_{stop} , confirm this.

We can make a quick estimate of how long will be needed. Let us begin with Equation (12B) above, which is the total primary current during the conducting phase. For convenient reference, it is repeated here:

$$i_p|_{total} \cong \left[\frac{V_0}{R_{\Sigma p}} - \sqrt{\frac{L_p}{L_s}} \left(\frac{V_d + v_c|_0}{R_{\Sigma p}} \right) \right] + \frac{1}{\tau_s} \left[\sqrt{\frac{L_p}{L_s}} (V_d + v_c|_0) - \frac{\tau_p}{\tau_{RC}} V_0 \right] t \quad (12B)$$

One of the observations we have already made is that this current does not change materially during the conducting phase. At time $t = T_{stop}$, it is still equal to its initial value (within four decimal places). We can therefore make the approximation:

$$i_p|_{total}(t = T_{stop}) \approx \frac{V_0}{R_{\Sigma p}} - \sqrt{\frac{L_p}{L_s}} \left(\frac{V_d + v_c|_0}{R_{\Sigma p}} \right) \quad (16)$$

After time $t = T_{stop}$, $i_p|_{total}$ and i_p are the same (there being no secondary current). Therefore, this value is also the initial condition for the magnetizing current i_p for the non-conducting phase.

Evaluating Equation (15) at the start of the non-conducting phase gives:

$$\begin{aligned} i_p(t_{non-conducting} = 0) &= i_p|_{total}(t_{conducting} = T_{stop}) \\ \rightarrow X e^0 + \frac{V_0}{R_{\Sigma p}} &\approx \frac{V_0}{R_{\Sigma p}} - \sqrt{\frac{L_p}{L_s}} \left(\frac{V_d + v_c|_0}{R_{\Sigma p}} \right) \\ \rightarrow X &= - \sqrt{\frac{L_p}{L_s}} \left(\frac{V_d + v_c|_0}{R_{\Sigma p}} \right) \end{aligned}$$

so, the complete expression for i_p is:

$$i_p = \frac{V_0}{R_{\Sigma p}} - \sqrt{\frac{L_p}{L_s}} \left(\frac{V_d + v_c|_0}{R_{\Sigma p}} \right) e^{-\frac{t_{non-conducting}}{\tau_p}} \quad (17)$$

Suppose we declare that the non-conducting phase ends when i_p rises to within, say, $1\% = 0.01$, of its steady-state value. We will call that time $t_{non-conducting} = T_{end}$. Then:

$$\begin{aligned}
0.01 &= \frac{i_p|_{steady-state} - i_p(t = T_{end})}{i_p|_{steady-state}} \\
&= \frac{\frac{V_0}{R_{\Sigma p}} - \left(\frac{V_0}{R_{\Sigma p}} - \sqrt{\frac{L_p}{L_s}} \left(\frac{V_d + v_c|_0}{R_{\Sigma p}} \right) e^{-\frac{T_{end}}{\tau_p}} \right)}{\frac{V_0}{R_{\Sigma p}}} \\
\rightarrow 0.01 \frac{V_0}{R_{\Sigma p}} &= \sqrt{\frac{L_p}{L_s}} \left(\frac{V_d + v_c|_0}{R_{\Sigma p}} \right) e^{-\frac{T_{end}}{\tau_p}} \\
\rightarrow e^{\frac{T_{end}}{\tau_p}} &= \frac{\sqrt{\frac{L_p}{L_s}} \left(\frac{V_d + v_c|_0}{R_{\Sigma p}} \right)}{0.01 \frac{V_0}{R_{\Sigma p}}} \\
\rightarrow T_{end} &= \tau_p \ln \left[\frac{\sqrt{\frac{L_p}{L_s}} \left(\frac{V_d + v_c|_0}{R_{\Sigma p}} \right)}{0.01 \frac{V_0}{R_{\Sigma p}}} \right] \quad (18)
\end{aligned}$$

As described above, this becomes a more important issue, and the length of time T_{end} becomes longer, as the load capacitor's initial voltage rises. Once $v_c|_0$ becomes larger than, say, 100V, this expression can be approximated as:

$$\begin{aligned}
T_{end} &\approx \tau_p \ln \left[\frac{\sqrt{\frac{L_p}{L_s}} \left(\frac{v_c|_0}{R_{\Sigma p}} \right)}{0.01 \frac{V_0}{R_{\Sigma p}}} \right] \text{ when } v_c|_0 \gg V_d \\
&= \tau_p \left[\ln \left(\frac{v_c|_0}{V_0} \right) + \ln \left(\sqrt{\frac{L_p}{L_s}} \right) - \ln 0.01 \right]
\end{aligned}$$

If the capacitor is initially charged to 1000V, for example, then the time needed for the non-conducting phase will be approximately equal to:

$$\begin{aligned}
T_{end} &\approx \tau_p \left[\ln \left(\frac{1000}{12} \right) + \ln \left(\sqrt{\frac{91.1\mu}{11.2}} \right) - \ln 0.01 \right] \\
&= \tau_p (4.423 - 5.860 + 4.605) \\
&= 3.168\tau_p
\end{aligned}$$

If the capacitor is initially charged to 1000V, then, it will take just over three time-constants, or 47.2 μ s, for the circuit to run through the non-conducting phase. That assumes, of course, that there is a non-

conducting phase. We do have some control over the matter. It would be useful to avoid the non-conducting phase altogether. Once diode D_1 stops conducting, the load capacitor is no longer charging. There is no need or benefit to remaining in the charging cycle once diode D_1 stops conducting. The sooner we can “reset” the circuit and start a new charging cycle, the better. We will look at ways to do this below.

Part #2 – A single discharging cycle

During the charging cycle, a substantial current flows through the primary circuit. If the non-conducting phase of the charging cycle is allowed to run to completion, then the primary current will rise all the way to its steady-state value. “Resetting” the circuit means bringing the primary current back down to zero, from which condition we can begin another charging cycle. Opening switch S_1 in the schematic diagram above, which is equivalent to turning off the MOSFET, will reset the circuit. However, before going too far down this route, let us look at a small part of the circuit, in and around the MOSFET. The following diagram shows the conceptual functions of switch S_1 in a little more detail.

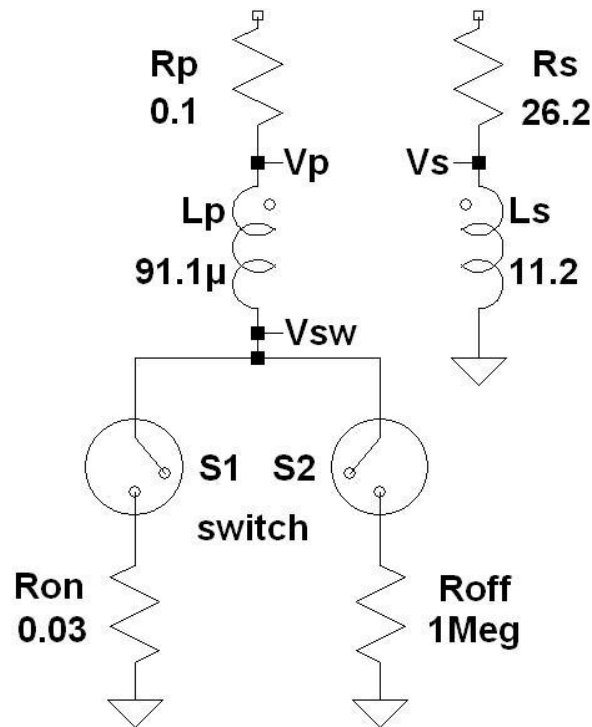

In this conceptual diagram, the two modes of operation of the MOSFET – its ON and OFF modes – are represented by separate switches – S_1 and S_2 – of which one is closed when the other is open. During a charging cycle, switch S_1 is closed and switch S_2 is open. The MOSFET’s 0.03Ω ON-resistance is a part of the primary circuit. Current will build up. If we let the charging cycle run through the conducting phase and the subsequent non-conducting phase, all the way to the circuit’s steady-state, the current flowing through switch S_1 will reach approximately 2A.

Then, we open switch S_1 to allow the primary circuit to “discharge”. Since the two switches represent the ON and OFF states of the MOSFET, opening switch S_1 is tantamount to closing switch S_2 . The MOSFET’s OFF-resistance, in the order of $1M\Omega$, say, will now be a series resistance in the primary circuit.

However, the magnetizing current flowing through the primary winding cannot, and will not, change instantaneously. But, the magnetic field which had been built up in and around the primary winding will start to collapse. The energy which had been stored in the magnetic field will start to be released into the primary circuit in the form of current. The magnetic field will collapse at whatever rate is needed to maintain the flow of current at its prior value, 2A. The only route this current can take is through the other components in the primary circuit, which components now include the OFF-resistance of the MOSFET R_{off} .

An enormous voltage will be developed over switch S_2 as this current is forced to flow through it. This will drive the undotted end of the winding, at voltage point v_{sw} in the schematic, wildly negative. The transformer will step up the primary voltage drop in the normal manner and the voltage drop over the secondary winding will also go wildly negative.

Diode D_1 will be reverse-biased (if it does not break down), so no current will flow in the secondary circuit.

We need to avoid this voltage spike, which we can do by providing an alternative route for current to take as the magnetic field of the primary winding collapses.

The following schematic diagram shows diode D_2 , which has been introduced to “discharge” the primary winding when the primary circuit is cut off. This diode is wired around the ideal inductance L_p and around its series resistance R_p , which is not a physically separate component.

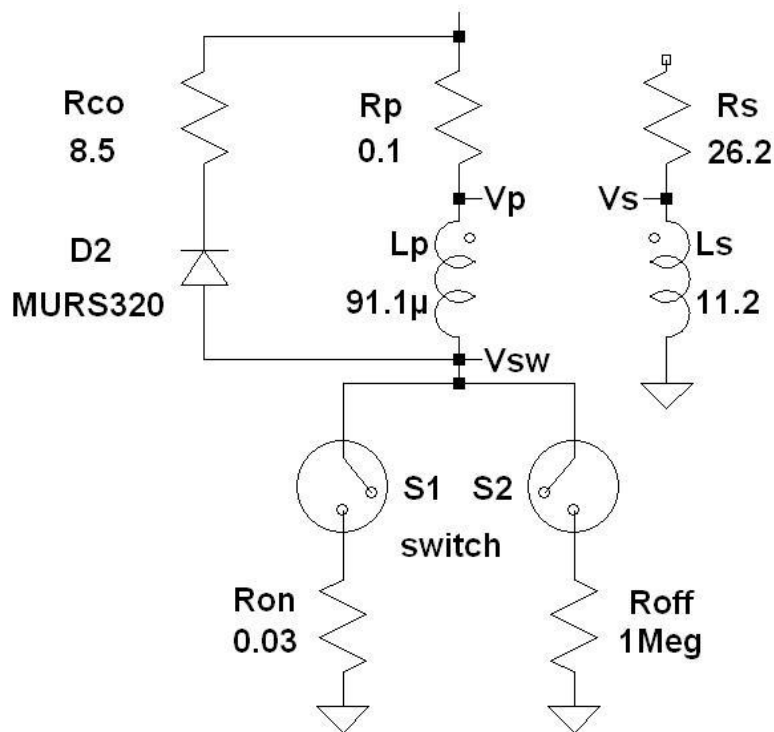

Resistor R_{co} (where the subscript “co” stands for cut off) has been placed in series with diode D_2 . The value of R_{co} , of 8.5Ω , is not arbitrary. It has been selected as the best compromise between two competing goals.

The first goal is to limit the negative voltage drops over the primary and secondary windings. If the steady-state current $i_{SS} = V_0/R_{\Sigma p}$ is driven entirely through resistor R_{co} when the magnetic field collapses, then the voltage drop over R_{co} will be (using Ohm's Law) $R_{co}i_{SS}$. Using our component values, the steady-state current of 2A will develop a voltage of 17V. The secondary voltage drop will be $\sqrt{L_s/L_p} = \sqrt{11.2/91.1\mu} = 351$ times greater, or 6.0KV. This might still be too high, but we certainly would not want it any higher. This sets one limitation, that R_{co} should be 8.5Ω, or less.

The second goal is to expend the energy in the magnetic field as quickly as possible. Time spent re-setting the primary current to zero is time not spent on the next charging cycle. The time-constant by which the current will burn off the energy in the magnetic field will be the usual inductor-resistor time-constant, $L_p/R_{co} = 91.1\mu/8.5 \cong 10.72\mu s$. We need to allow about five times as long, or 53.6μs, for the current to decay, exponentially, to zero. This may be longer than we would like, but we certainly would not want it any longer. This sets a competing limitation, that R_{co} should be 8.5Ω, or more. Caught between these two limits, let us set resistor R_{co} to 8.5Ω.

The circuit whose discharge cycle we will analyze is shown in the following schematic diagram.

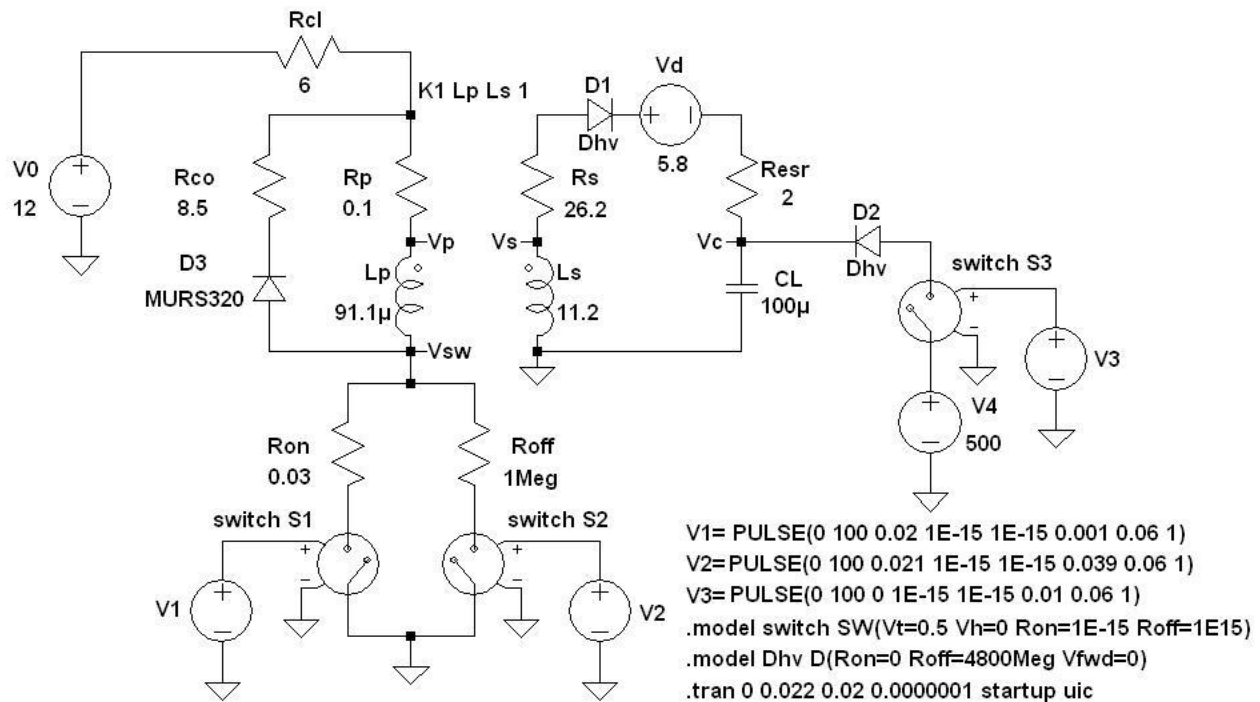

As before, diode D_2 and its associated components charge up the capacitor to the desired initial voltage. This process occurs during the first 20ms of the simulation. At simulation time $t_{sim} = 20ms$, voltage source V_1 goes high and closes switch S_1 . This represents the MOSFET's ON-mode and the beginning of the charging cycle. The SPICE directives show that switch S_1 is left closed for 1ms. (I chose to leave the MOSFET ON for 1ms simply because 1ms is longer than needed for a complete charging cycle at any initial voltage over the load capacitor.) At simulation time $t_{sim} = 21ms$, switch S_1 opens and switch S_2 closes. The discharging cycle begins at this instant. For the following mathematical analysis, this instant, at which switch S_2 closes, is used as the time-base $t = 0$.

We can simplify the six circuit equations for the discharging cycle by recognizing that there will be virtually no current flowing through the MOSFET. The value of R_{off} shown, of 1MΩ, was selected

rather arbitrarily. For analysis purposes, we will simply leave the primary circuit as an open circuit. Note that this will cause the circuit variable $i_p|_{total}$ to be identically equal to zero.

We also need to introduce a new circuit variable $i_p|_{co}$ for the current flowing through diode D_3 , which we will assume to be positive when the current flows in this diode forward-conduction direction, which is upwards in the schematic diagram.

With these changes, we can write down the circuit equations which apply during the discharging cycle.

Sum of the voltage drops around the primary circuit

$$-R_{co}i_p|_{co} = (v_p - v_{sw}) + R_p i_p|_{co} \quad (19A)$$

Sum of the currents flowing through the primary winding

The current flowing through the primary winding will be the sum of: (i) the magnetizing current i_p and (ii) the current flowing through the secondary circuit, scaled up by the turns-ratio. Since no current will be flowing in the secondary circuit during the discharging cycle, this reduces to:

$$i_p|_{co} = i_p \quad (19B)$$

The magnetizing current of the primary winding

The magnetizing current is determined by the self-inductance of the primary winding. It is related to the voltage drop over the primary winding by:

$$v_p - v_{sw} = L_p \frac{di_p}{dt} \quad (19C)$$

The ratio of voltages between the two sides of the transformer

The voltage drops over the ideal inductances of the transformer are related by the turns-ratio, thus:

$$v_s = \sqrt{\frac{L_s}{L_p}} (v_p - v_{sw}) \quad (19D)$$

Combining the first three of these equations gives a first-order differential equation in the circuit variable i_p :

$$L_p \frac{di_p}{dt} + (R_{co} + R_p)i_p = 0$$

We can define another time-constant, the ‘‘cut-off’’ time-constant, as follows:

$$\tau_{co} = \frac{L_p}{R_{co} + R_p} = \frac{91.1\mu}{8.5 + 0.1} = 10.59\mu\text{s} \quad (20)$$

Then, the differential equation can then be written as:

$$\tau_{co} \frac{di_p}{dt} + i_p = 0 \quad (21)$$

which has the solution:

$$i_p = P e^{-\frac{t}{\tau_{co}}} \quad (22)$$

Now, let us look at the initial condition. Since the magnetizing current flowing through the primary winding cannot change instantaneously upon switches S_1 and S_2 changing state, the magnetizing current i_p will initially be equal to the steady-state current, thus:

$$\begin{aligned} i_p(t=0) &= \frac{V_0}{R_{\Sigma p}} \\ \rightarrow P e^0 &= \frac{V_0}{R_{\Sigma p}} \\ \rightarrow P &= \frac{V_0}{R_{\Sigma p}} \end{aligned}$$

Therefore, the complete expressions for the circuit variables are:

$$\text{from Equation (22)} \quad i_p = \frac{V_0}{R_{\Sigma p}} e^{-\frac{t}{\tau_{co}}} \quad (23A)$$

$$\text{from Equation (19B)} \quad i_p|_{co} = \frac{V_0}{R_{\Sigma p}} e^{-\frac{t}{\tau_{co}}} \quad (23B)$$

$$\text{from Equation (19C)} \quad v_p - v_{sw} = -\frac{L_p}{\tau_{co}} \frac{V_0}{R_{\Sigma p}} e^{-\frac{t}{\tau_{co}}} = -\left(\frac{R_{co} + R_p}{R_{\Sigma p}}\right) V_0 e^{-\frac{t}{\tau_{co}}} \quad (23C)$$

$$\text{from Equation (19D)} \quad v_s = -\sqrt{\frac{L_s}{L_p}} \left(\frac{R_{co} + R_p}{R_{\Sigma p}}\right) V_0 e^{-\frac{t}{\tau_{co}}} \quad (23D)$$

Using our component values, the initial values of the circuit variables are:

$$\begin{aligned} i_p(t=0) &= \frac{12}{6.13} = 1.958A \\ i_p|_{co}(t=0) &= \frac{12}{6.13} = 1.958A \\ (v_p - v_{sw})(t=0) &= -\left(\frac{8.5 + 0.1}{6.13}\right) 12 = -16.84V \\ v_s(t=0) &= -\sqrt{\frac{11.2}{91.1\mu}} (16.84) = -5905V \end{aligned}$$

The following two graphs show the results of the SPICE simulation, starting from the instant when switch S_1 is closed. For the run shown, the initial voltage over the load capacitor was 500V. The first graph shows the primary voltage drop $v_p - v_{sw}$.

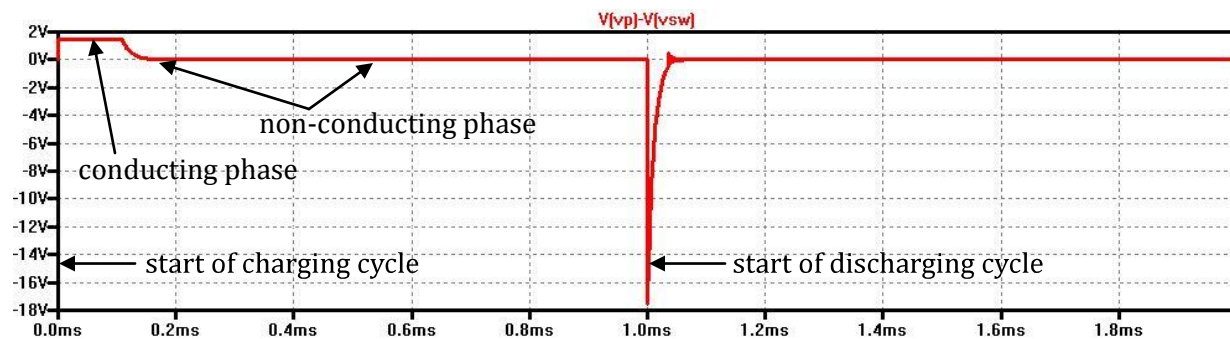

We calculated above that the primary voltage drop is about 1.443V during the conducting phase of the charging cycle, which lasts for about 108.7 μ s. The primary voltage drop falls to zero during the non-conducting phase of the charging cycle, and remains zero for the rest of the charging cycle. The discharging cycle starts at time 1ms in the graph. At that time, the primary voltage drop plunges to minus 17.5V. This negative voltage drop is slightly more than we just calculated.

The following graph shows the secondary voltage drop $V(vs)$ and the current flowing through the cut-off resistor $I(Rp)$.

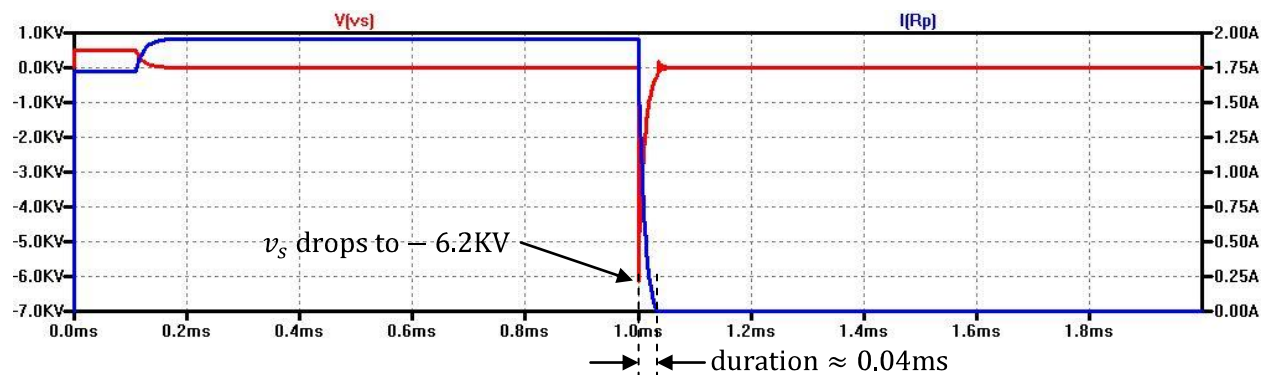

The duration of the discharging cycle looks to be about 40 μ s on the graph, slightly less than we calculated.

The differences between the waveforms in the graphs and our calculations are probably the result of the fact that we treated diode D_3 as a perfect ideal diode in the circuit equations. We ignored both its forward voltage drop and its forward resistance. Ignoring the diode's forward voltage drop means that it will take a little longer for current to start flowing through R_{co} than we had planned, meaning that the voltage overshoot will be a little greater than we had planned. Ignoring the diode's forward resistance means that the energy from the collapsing magnetic field will be burned off a little more quickly than we had planned and the discharging cycle will be completed a little more quickly than we had planned.

The D_3 diode used in the SPICE simulation is a MURS320. It is an ultra-fast power diode specifically designed for "free-wheeling" applications like this one. It can handle 3A continuously with a forward voltage drop of about 1.3V. Its reverse recovery time should not be more than about 75ns.

Part #3 – Efficiency

In this section, we will begin to examine the efficiency with which energy is transferred from the power supply into the load capacitor. In order that the analysis does not get out of hand, we will look at a single charging cycle and its following discharging cycle, where the load capacitor starts out with an initial voltage of $v_c|_0$. In order to simplify things a little bit more, we will also restrict our attention to initial capacitor voltages that are much greater than $V_d = 5.8V$. We can then approximate the duration of the conducting phase of the charging cycle [Equation (13)] as follows:

$$T_{stop} = \frac{\frac{V_0}{R_{\Sigma p}} - \sqrt{\frac{L_p}{L_s}} \left(\frac{V_d + v_c|_0}{R_{\Sigma p}} \right)}{\left(\frac{V_d + v_c|_0}{\sqrt{L_p L_s}} \right) + \frac{1}{\tau_s} \frac{V_0}{R_{\Sigma p}}} \cong \frac{\frac{V_0}{R_{\Sigma p}}}{\left(\frac{v_c|_0}{\sqrt{L_p L_s}} \right) + \frac{1}{\tau_s} \frac{V_0}{R_{\Sigma p}}} \quad (24)$$

The numerator has been approximated as we did above, by noting that the turns-ratio $\sqrt{L_s/L_p}$ is very large. The denominator has been approximated using the assumption that $V_d \ll v_c|_0$.

During the conducting phase of the charging cycle, the power supply delivers current of $i_p|_{total}$. Equation (12B) sets out the expression for $i_p|_{total}$ which applies during this period. We have seen that this current is approximately constant during the conducting phase. We can, therefore, approximate $i_p|_{total}$ with its value at the start of the conducting phase. This value is:

$$i_p|_{total} \cong \frac{V_0}{R_{\Sigma p}} - \sqrt{\frac{L_p}{L_s}} \left(\frac{V_d + v_c|_0}{R_{\Sigma p}} \right) \cong \frac{V_0}{R_{\Sigma p}} - \sqrt{\frac{L_p}{L_s}} \left(\frac{v_c|_0}{R_{\Sigma p}} \right) \quad (25)$$

The instantaneous power supplied by the power supply is, as always, equal to the voltage V_0 multiplied by the instantaneous current $i_p|_{total}$. To the extent that the instantaneous current is constant, the instantaneous power will be constant, too. The total amount of energy E_{PS} which the power supply delivers during the complete conducting phase of the charging cycle can therefore be written as:

$$\begin{aligned} E_{PS} &= (V_0 \times i_p|_{total}) \times T_{stop} \\ &\cong V_0 \left[\frac{V_0}{R_{\Sigma p}} - \sqrt{\frac{L_p}{L_s}} \left(\frac{v_c|_0}{R_{\Sigma p}} \right) \right] \left[\frac{\frac{V_0}{R_{\Sigma p}}}{\left(\frac{v_c|_0}{\sqrt{L_p L_s}} \right) + \frac{1}{\tau_s} \frac{V_0}{R_{\Sigma p}}} \right] \quad (26) \end{aligned}$$

Now, let us look at the current i_s flowing in the secondary circuit during the conducting phase of the charging cycle. Equation (12C) sets out the expression for i_s which applies during this period. We have seen that the waveform is a linear decline, from some initial value to zero, in a time period equal to T_{stop} . The average current is therefore equal to one-half of the initial value, or:

$$i_s|_{avg} \cong \frac{1}{2} \sqrt{\frac{L_p}{L_s}} \left[\frac{V_0}{R_{\Sigma p}} - \sqrt{\frac{L_p}{L_s}} \left(\frac{V_{c|0} + v_c|_0}{R_{\Sigma p}} \right) \right] \cong \frac{1}{2} \sqrt{\frac{L_p}{L_s}} \left[\frac{V_0}{R_{\Sigma p}} - \sqrt{\frac{L_p}{L_s}} (v_c|_0) \right] \quad (27)$$

Now, as always, the total amount of charge ΔQ which is carried by current $i_s|_{avg}$ in time T_{stop} is equal to:

$$\begin{aligned} \Delta Q &= i_s|_{avg} \times T_{stop} \\ &\cong \frac{1}{2} \sqrt{\frac{L_p}{L_s}} \left[\frac{V_0}{R_{\Sigma p}} - \sqrt{\frac{L_p}{L_s}} (v_c|_0) \right] \left[\frac{\frac{V_0}{R_{\Sigma p}}}{\left(\frac{v_c|_0}{\sqrt{L_p L_s}} \right) + \frac{1}{\tau_s} \frac{V_0}{R_{\Sigma p}}} \right] \quad (28) \end{aligned}$$

All of this charge ΔQ is added to the capacitor. We can calculate how much energy this added charge represents. Recall that the energy stored in a capacitance C charged to voltage V is equal to $\frac{1}{2}CV^2$. Recall also that the charge stored in a capacitance C when it is charged to voltage V is equal to CV . We can work with these two relationships as follows.

At the start of the charging cycle, when charged to voltage $v_c|_0$, the load capacitor C_L holds charge Q_0 equal to:

$$Q_0 = C_L v_c|_0 \quad (29A)$$

During the conducting phase, charge ΔQ is added to the load capacitor, so its ending charge Q' is equal to:

$$Q' = Q_0 + \Delta Q \quad (29B)$$

The load capacitor's ending voltage v'_c will be equal to:

$$\begin{aligned} v'_c &= \frac{Q'}{C_L} \\ &= \frac{Q_0 + \Delta Q}{C_L} \\ &= v_c|_0 + \frac{\Delta Q}{C_L} \quad (30) \end{aligned}$$

The increase ΔE_{C_L} in the capacitor's stored energy during the conducting phase is equal to the end at the end of the period less the energy at the start of the period, thus:

$$\begin{aligned} \Delta E_{C_L} &= \frac{1}{2} C_L (v'_c)^2 - \frac{1}{2} C_L (v_c|_0)^2 \\ &= \frac{1}{2} C_L \left[\left(v_c|_0 + \frac{\Delta Q}{C_L} \right)^2 - (v_c|_0)^2 \right] \\ &= \frac{1}{2} C_L \left[2v_c|_0 \frac{\Delta Q}{C_L} + \left(\frac{\Delta Q}{C_L} \right)^2 \right] \end{aligned}$$

And, continuing:

$$\begin{aligned}\Delta E_{C_L} &= \frac{1}{2} \Delta Q \left(2v_c|_0 + \frac{\Delta Q}{C_L} \right) \\ &\cong \Delta Q v_c|_0 \text{ if } \Delta Q \ll C_L v_c|_0 \quad (31)\end{aligned}$$

ΔE_{C_L} is the energy added to the capacitor during the conducting phase; E_{PS} is the energy supplied by the power supply during the same period. The fraction of the energy supplied which is added to the capacitor is therefore equal to:

$$\begin{aligned}\frac{\Delta E_{C_L}}{E_{PS}} &\cong \frac{\frac{1}{2} v_c|_0 \sqrt{\frac{L_p}{L_s}} \left[\frac{V_0}{R_{\Sigma p}} - \sqrt{\frac{L_p}{L_s}} (v_c|_0) \right] \left[\frac{\frac{V_0}{R_{\Sigma p}}}{\left(\frac{v_c|_0}{\sqrt{L_p L_s}} \right) + \frac{1}{\tau_s} \frac{V_0}{R_{\Sigma p}}} \right]}{V_0 \left[\frac{V_0}{R_{\Sigma p}} - \sqrt{\frac{L_p}{L_s}} \left(\frac{v_c|_0}{R_{\Sigma p}} \right) \right] \left[\frac{\frac{V_0}{R_{\Sigma p}}}{\left(\frac{v_c|_0}{\sqrt{L_p L_s}} \right) + \frac{1}{\tau_s} \frac{V_0}{R_{\Sigma p}}} \right]} \\ &= \frac{1}{2} \sqrt{\frac{L_p}{L_s}} \left(\frac{v_c|_0}{V_0} \right) \quad (32)\end{aligned}$$

The factor $\sqrt{L_p/L_s} = \sqrt{91.1\mu/11.2} = 0.00285$. Dividing by 2 reduces the factor to 0.00143. The transfer efficiency for various initial capacitor voltages can be calculated as follows:

$v_c _0 \rightarrow$	500V	1000V	2000V	3000V	4000V
$\frac{\Delta E_{C_L}}{E_{PS}} =$	6.0%	11.9%	23.8%	35.8%	47.7%

These are the efficiencies during the conducting phase only of the charging cycle. Should the charging cycle continue on to its non-conducting phase, things get worse. The power supply continues to deliver current, and an increasing amount of current at that, none of which adds energy to the capacitor. Similarly, during the discharging cycle, no energy is added to the load capacitor. Happily, though, the power supply does not supply any power during the discharging cycle. The lesson to take away is that the non-conducting phase must be kept limited in duration, or perhaps avoided all together. If that is done, then the efficiency of the circuit, which starts off very low, increases to a maximum of 50% as the voltage over the load capacitor approaches the maximum permitted by the transformer.

Part 4 – Adding a real MOSFET

In this part, we will insert a real switch – an n-channel enhancement-mode MOSFET, the IFRP4886 from International Rectifier – into the circuit. The MOSFET is shown as component M in the following schematic diagram, along with its driver transistor Q . The schematic still does not have a real timing sub-circuit, and the base of the driver transistor Q is controlled simply by the pulsed voltage supply V_3 .

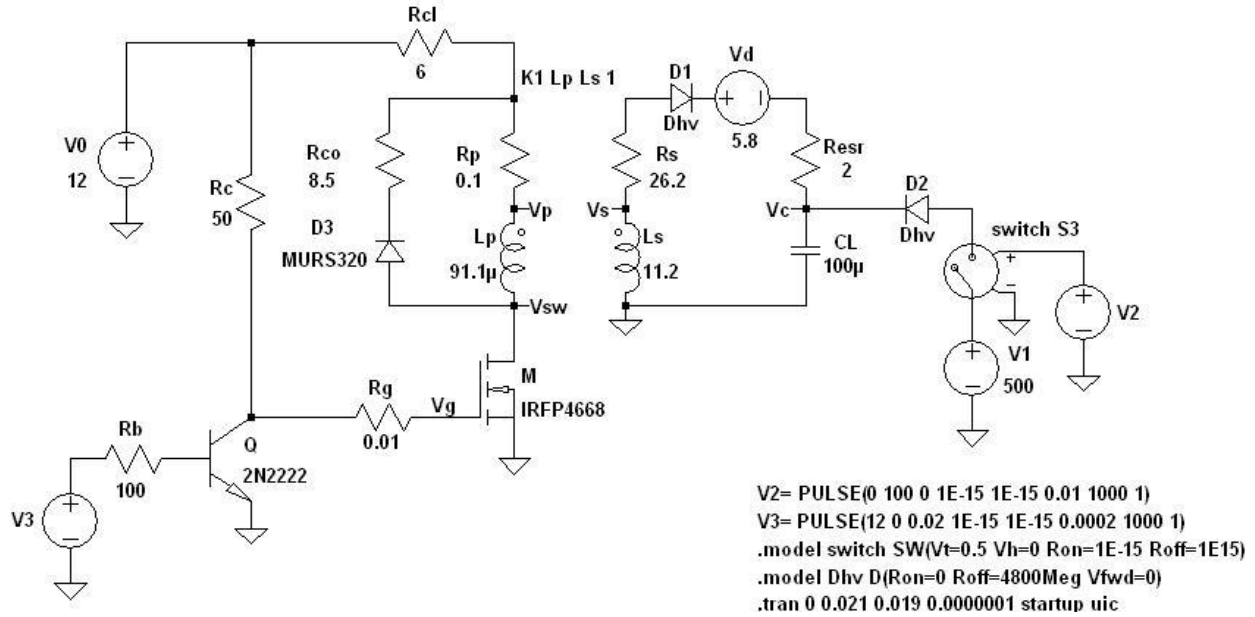

The resistances R_{on} and R_{off} are now gone from the schematic, having been incorporated as properties of the IRFP4886. Charge is delivered to the IRFP4886's gate through resistor R_g , which is connected to the collector of its driver transistor Q , a common 2N2222 npn transistor. When transistor Q is active, or in its saturation mode, its collector is pulled down to ground potential. This turns off the MOSFET.

For simulation purposes, transistor Q 's base is driven directly by voltage source V_3 . V_3 has a nominal voltage of 12V. Note the SPICE directive for V_3 . At the start of the simulation, V_3 is high, putting transistor Q into saturation, and cutting off the MOSFET. As has been done before, the first 20ms of the simulation is the time period during which the load capacitor is charged up to its initial voltage, in this case, 500V, through diode D_2 and its associated components.

20ms into the simulation, voltage source V_3 goes low. As will be explained below, this allows M 's gate to drift high. Current will begin to flow through the primary circuit. This is the start of the charging cycle.

200µs later, at simulation time 20.2ms, voltage source V_3 goes high once again. This cuts off the primary circuit and begins the discharging cycle. The results of the simulation are graphed for the 2ms period starting 19ms into the simulation. We will look at the waveforms after we figure out what should be expected.

The value of Q 's base resistor R_b has been selected to limit the current flowing into Q 's base to 100mA or so. The datasheet for the 2N2222 shows that its base-emitter saturation voltage can be as high as 2V when the base is sinking 50mA. If the base-emitter voltage is 2V, then the voltage drop over R_b will be $12V - 2V = 10V$ and the current flowing through R_b will be equal to $10V/100\Omega = 100mA$.

When voltage source V_3 is high, at a voltage of 12V, transistor Q will be forward-biased. If it operates in its linear region, then its collector current should be equal to the base current multiplied by the transistor's dc-current gain h_{FE} . The datasheet for the 2N2222 shows that its dc-current gain is typically in the range 35-100. Even with the minimum value of dc-current gain (35), the voltage drop over the collector resistor R_c would be equal to $35 \times 50\Omega \times 100mA = 175V$. This is not possible. The impossibility will be resolved as follows: transistor Q will not operate in its linear region, but in its saturation mode.

The datasheet for the 2N2222 shows that its collector-emitter voltage is a maximum of 1V when the base current is 50mA.

What all of this means is that, when the control voltage V_3 is high, the IRFP4886's gate will in effect be connected to a 1V voltage source through gate resistor $R_g = 0.01\Omega$. This should drain away the charge on the MOSFET's gate and turn it off.

Now, let us look at the case when the control voltage V_3 goes low. Transistor Q will be cut off. In its cut-off state, its collector terminal is free to float, and the voltage to which it will drift is determined by the circuitry outside of the transistor. In our case, the collector terminal will be pulled up to the supply voltage (V_0) by the collector resistor R_c . The IRFP4886's gate will then be connected to a 12V voltage source through the series combination of R_c and R_g . This should charge up the MOSFET's gate and turn it on.

The principal characteristic of the MOSFET's gate is its capacitance, and the charge it carries. Whereas a bipolar transistor is "on" when current flows into its base, a MOSFET is "on" when its gate capacitance is charged up. The speed with which the MOSFET is turned "on" or "off" is determined by the speed with which charge is added to, or removed from, its gate capacitance. The datasheet for the IRFP4886 shows that: (i) its total gate charge is typically 161nC, and (ii) its input capacitance is typically 10.72nF. Note that these two measures are only consistent at a voltage of $V = Q/C = 15V$. I am told that it is better practice to use the gate charge in calculations and not to rely on the gate capacitance.

The following sub-schematics show the essential features of the circuit when the IRFP4886 gate is discharging (on the left) and charging (on the right).

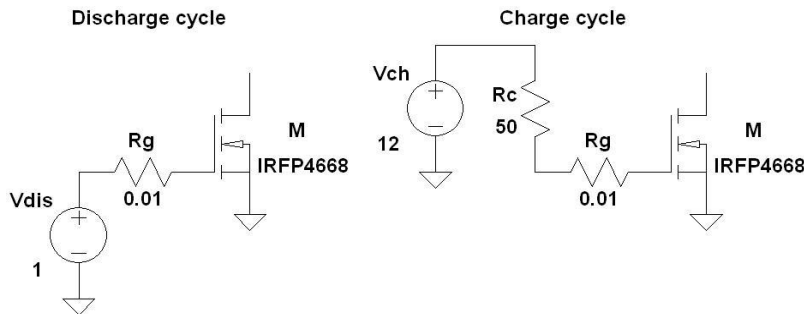

If the gate capacitance is 10.72nF, then the gate will discharge through resistor R_g with a time-constant of $RC = 0.01 \times 10.72n = 0.11ns$. This is extremely fast. If the gate is initially charged up to 12V, then the initial discharge current will be $12V/0.01\Omega = 1200A$. This is extremely high, but the current will not last very long. In any event, the gate will be completely discharged within five time-constants or so, which is approximately one-half nanosecond.

On the other hand, when charging, the gate will charge up through the series resistance of R_c and R_g with a time-constant of $RC = 50.01 \times 10.72n = 536ns$. If the gate is initially at zero volts, then the initial charging current will be $12V/50.01\Omega = 240mA$. In any event, the gate will charge up within five time-constants, being 2.5 μs or thereabouts.

From an overall point-of-view, one can say that the MOSFET's gate is pulled down when transistor Q is turned on and allowed to float up when transistor Q is turned off. It would be possible to add another transistor, in a push-pull configuration with Q , so that the MOSFET's gate is both pushed and pulled. I do not believe this addition is necessary – the charge and discharge times seem to be suitably fast.

The following graph shows the result of the SPICE simulation. The variables shown are the MOSFET's gate voltage v_g (being the SPICE variable V(vg), shown in blue), the primary current flowing through resistor R_p (being the SPICE variable I(Rp), shown in red) and the secondary current flowing through diode D_1 (being the SPICE variable I(D1), shown in gray). Note that the secondary current is multiplied by 1000 for display purposes – the secondary current starts off at just under 5.0mA.

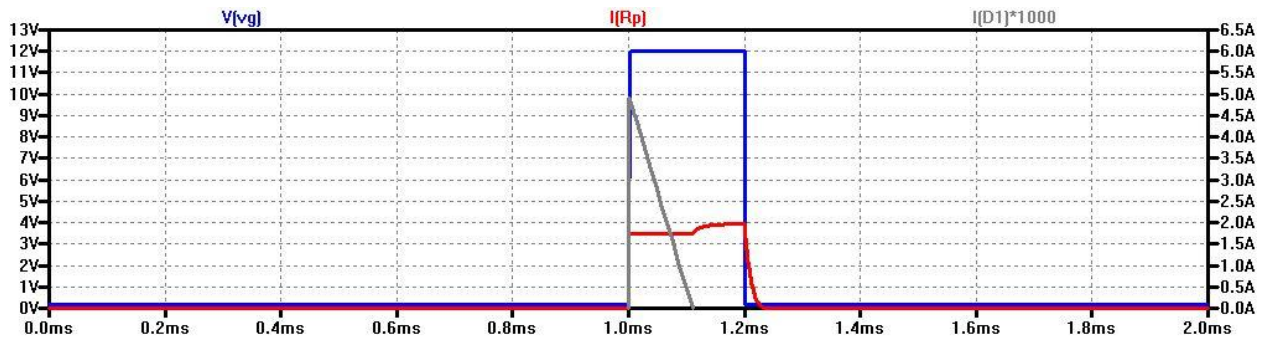

All is as expected. The gate voltage rises from zero to 12V in a time frame too short to show on the graph. Once the MOSFET is turned on, the primary current is (approximately) constant while current flows in the secondary circuit. As soon as the secondary circuit stops charging the load capacitor, the primary current rises to its steady-state value. When transistor Q is then turned on, the MOSFET's gate voltage decreases to zero instantaneously, at least on the scale visible in the chart. This begins the discharging cycle, during which the energy stored in the magnetic field is dissipated by current flowing through resistor R_{co} .

Part 5 – Asynchronous operation with a 555 timer

In this section, we will add a sub-circuit to control the timing. We will use a 555 timer wired for astable, or cyclic, operation. The timer will generate pulses having a fixed length and a fixed duty cycle. Choosing the best lengths for the “on”-time and the “off”-time is going to require some compromise and therefore some loss of efficiency.

The discharging cycle should not be too much of a problem. Recall that the power supply does not supply any power during the discharging cycle, so no power is wasted *per se* during the discharging cycle. We can easily configure the 555 timer to generate pulses 53.0 μ s long, which will allow five τ_{co} time-constants for the discharging cycle. Furthermore, the length of the discharging cycle does not depend on the load capacitor's initial voltage, so the same length of pulse can be used for the entire operation.

The charging cycle presents more of a challenge. The length of the charging cycle does depend on the capacitor's initial voltage. In fact, the length of the discharging cycle varies widely. It is 10.48ms when the capacitor is uncharged, decreases to 108.7 μ s when the capacitor is charged to 500V and decreases all the way down to 5.941 μ s when the capacitor reaches 3000V. No single length of charging time can suit all capacitor voltages. So, what should we do?

If we end a charging cycle before the time T_{stop} which applies for the capacitor's current voltage level, then we waste time. The secondary circuit was ready, willing and able to add more charge to the load capacitor, but we, by stopping the cycle early, did not permit it.

On the other hand, if we wait until after T_{stop} before starting the discharge, then we waste energy in the non-conducting phase of the charging cycle, as well as wasting time.

Somewhat arbitrarily, I have selected a charging period of $60\mu s$ and a discharging period of $50\mu s$. The capacitor voltage at which $60\mu s$ is the perfect T_{stop} is $829.3V$. At lower voltages, we waste time. At higher voltages, we waste energy and time.

The following schematic diagram shows the circuit which we will simulate in this section.

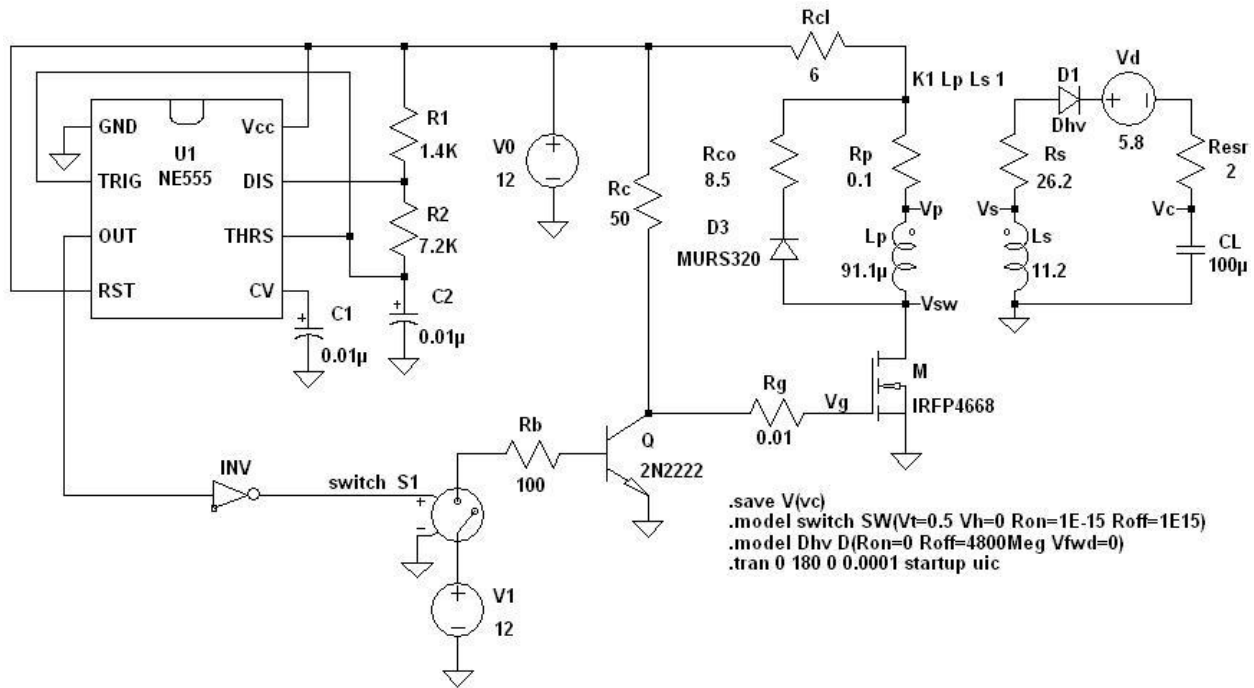

The 555 timer is wired as an astable. With the component values shown, its output pulse will have the following high and low times.

$$t_{high} = 0.693 \times (1.4K + 7.2K) \times 0.01\mu = 59.6\mu s$$

$$t_{low} = 0.693 \times 7.2K \times 0.01\mu = 49.9\mu s$$

We need the MOSFET's gate to be high for the duration of the 555's low pulse. That necessitates the inverter INV shown on the timer's output line. The limitations of my version of SPICE require that the inverter's output, which is a logical 0-1 output, be scaled to 12V by using switch S_1 and voltage source V_1 . In practice, a normal (12V) inverter would suffice.

The following graph is the result of the SPICE simulation for the first 180s (three minutes) of operation. The traces graphed are the voltage v_c over the capacitor (being the SPICE variable V(vC), shown in blue) and the energy $\frac{1}{2}C_L v_c^2$ stored in the capacitor (calculated using the formula on the graph, shown in red).

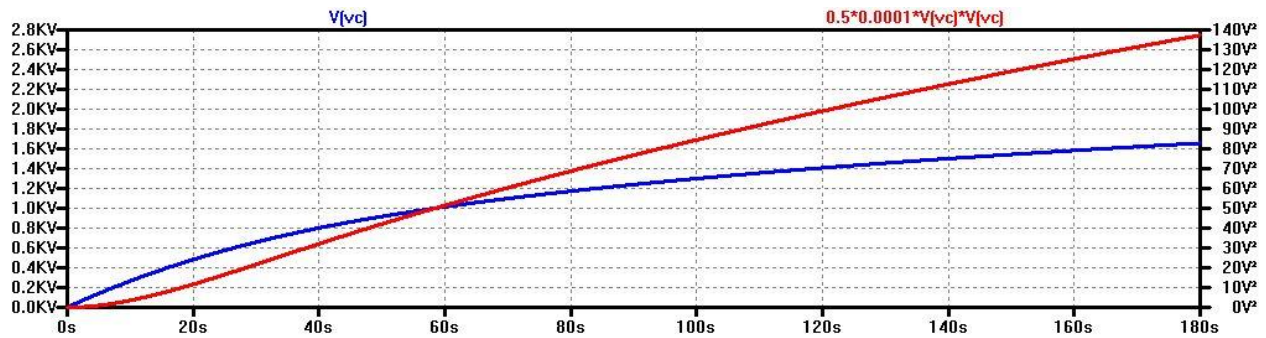

By the end of three minutes, the load capacitor has reached about 1650V and holds about 136J.

The following graph shows the continuation of the above waveform to 1800s (thirty minutes) of operation. At the end of thirty minutes, the capacitor has reached about 3150V and holds about 500J.

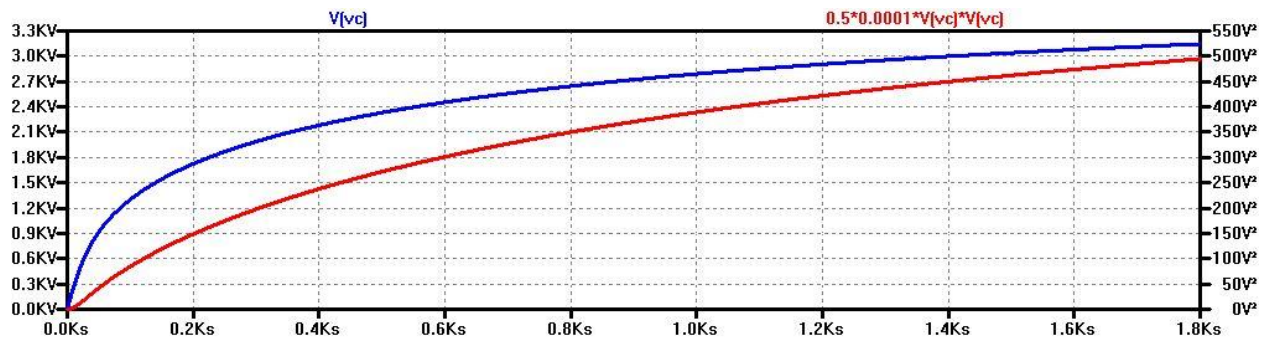

Part 6 – Where to go next?

The 555 timer is not a very effective way to control the timing in this circuit. The pulse controlling the charging cycle should not have a fixed length, but should decrease as the voltage over the load capacitor increase. There are asynchronous ways to do this, by which I mean ways to decrease the pulse length according to some plan which does not require that the voltage over the load capacitor be measured.

A better way, of course, would be some kind of feedback mechanism, which has as its input the voltage over the capacitor. Direct measurement is undesirable, since the secondary circuit operates at high voltages. An indirect measurement, using a third coil on the transformer, would be better.

However, there is another issue. This paper has been an examination of a “boost” type of circuit, in which current flows in the transformer’s secondary circuit at the same time as it flows in the primary circuit. This is the typical way in which transformers operate. But, it is not the only way. One of the fundamental deficiencies of this circuit is that it wastes the energy which is built up in the transformer during the charging cycle. At the end of the charging cycle, the MOSFET is turned off and the energy released by the collapse of the magnetic field is dissipated. In fact, we introduced resistor R_{co} for the specific purpose of “burning off” the energy in the form of heat. That is a waste and accounts for the fact that the maximum efficiency achievable by the circuit is only 50%.

The alternative approach is a “buck-boost” configuration. It is described in another paper, entitled *A High-Voltage “Buck-Boost” Capacitor Charger*. It has so many advantages over the “boost”-type charger that I have not examined the “boost” charger any further.

Jim Hawley
May 2012

An e-mail describing errors and omissions would be appreciated.

Appendix A

Layout of turns in the secondary winding

Step 1: Divide the core into four segments. No windings will be placed in segment A. Segments B, C and D are equal in size, and each encompasses one inch of the inner circumference. Segment A is slightly smaller, and encompasses 0.77 inch of the inner circumference.

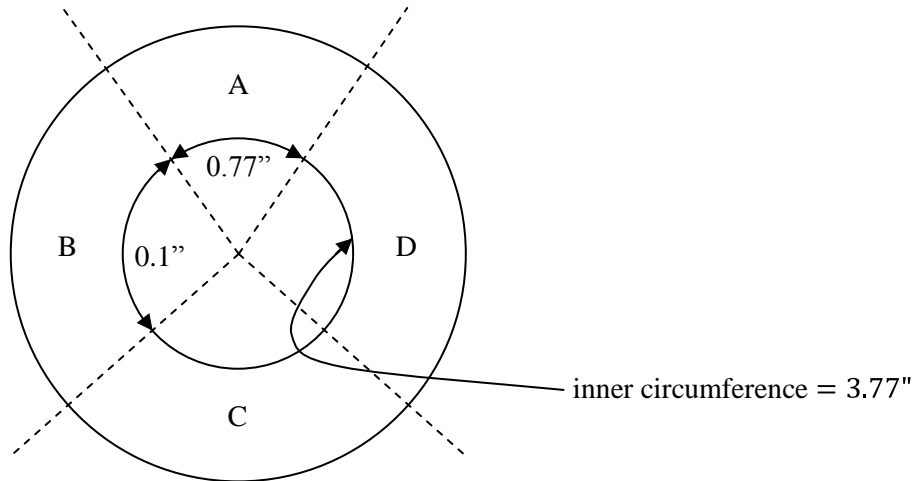

Step 2: Wind 350 turns on segment D before winding any turns on segments B or C. The 350 turns will be wound in five layers: 90 turns in the first layer, 75 turns in the second and third layers and 55 turns in the fourth and fifth layers. This is shown schematically as:

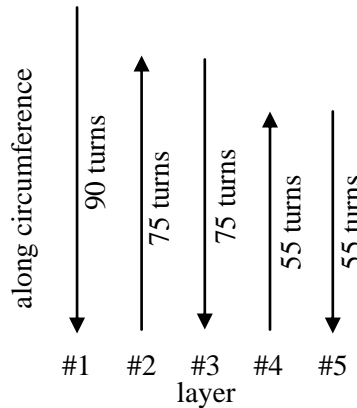

Step 3: Wind 350 turns on segment C before winding any turns on segment B.

Step 4: Wind 350 turns on segment B.

Because the total voltage drop of 4000V is divided into three separate segments, the voltage drops between adjacent turns will never exceed $4000V/3 = 1340V$.